

PREFERRED CLIP SUPPLIER
OF



BUILDING PRODUCTS DEVELOPMENT
STANDING SEAM CLIPS
& ACCESSORIES

WEGOTCLIPS.COM | (866) 766-3254

MORE THAN A CLIP SUPPLIER, BPD HAS BECOME THE INDUSTRY DESIGN COMPANY FOR IMPROVING OVERALL PERFORMANCE.



Welcome to Building Products Development, Inc.

Since inception, Building Products Development, Inc. (BPD) has focused on developing and producing state-of-the-art products for the metal construction industry. Our resources and expertise have allowed us to develop standing seam clips with exceptional performance that can easily be adapted to fit almost any standing seam profile.

More than a clip provider

We offer specialized services including clip development, technical and product applications. BPD boasts over 40 years experience in the metal construction industry, providing a unique advantage over other clip providers. Our professionals are experienced in all facets of the industry including roof design, testing, and fabrication. Our specialized services coupled with our extensive knowledge, offer our customers unparalleled support.

Commitment to Quality

The manufacturing facility producing these clips is ISO9001 Certified which assures you of regular audits on both material and workmanship. Clips are never made with material seconds or coil leftovers. When you buy from us, you are always getting ASTM specified prime steel.

Testing

BPD has established solid relationships with the leaders of the metal roofing industry enabling us to provide testing and support to all of our customers. We work with a certified independent testing laboratory, as well as our own in house laboratory to conduct many different tests. We can provide pull tests and ASTM tests, standing water tests, ASTM 1592 tests and air and water infiltration. Reports can be purchased through BPD, please call to discuss testing in detail.

Stamping Needs

BPD has developed unique tooling that can be economically modified to match your panel needs. If you do not find a clip in this catalog that fits, we may be able to develop and design a custom clip for you. More than clips, we also provide roof accessories and other stamped parts. If you have an idea for a new product, our design team would be happy to provide a quote to you.

Advantages of using BPD clips:

- Full line of standard clips
- Large selection stocked and ready for immediate delivery
- Many clips are UL listed
- Best overall clip value in the industry
- Custom clip and component design
- Design assistance to improve existing components
- No charge, fast prototyping
- We pay tooling costs for qualified customers
- Full performance testing available: UL, ASTM E1592, E1646, E1680



ZIMMERMAN

ALL DIMENSION ARE NOMINAL SIZES

SLC1000 : 1" Snaplock

SNAPLOCK CLIP		<i>500 per box 16,500 per skid</i>	
	GALVANIZED		
24 Ga.	SGZ2-100-24		

SLC1750 : 1-3/4" Snaplock

UL - SNAPLOCK CLIP			
PART #	QTY:		
SGUL-178-18 (Galvanized)	<i>250 per box 8250 per skid</i>		
SSUL-178-18 (Stainless Steel)			

SNAPLOCK CLIP			<i>500 per box 16,500 per skid</i>	
	GALVANIZED	STAINLESS STEEL		
18 Ga.	SG-178-18	SS-178-18		



ALL DIMENSION ARE NOMINAL SIZES

SS1000: 1" MECHANICAL LOCK

SS1000 : 1" Mechanical Lock

			FIXED	1,000 per box 33,000 per skid
	GALVANIZED	STAINLESS STEEL		
24 Ga.	FG-100-24	FS-100-24		
26 Ga.	FG-100-26	FS-100-26		

			FLOATING INTERLOCKING BASE	500 per box 33,000 per skid
	GALVANIZED	STAINLESS STEEL		<p style="text-align: center; font-size: small;">INTERLOCKING TAB REQUIRED</p>
22 Ga.	BG-300-22 w/o emboss	BS-300-22 w/o emboss		
	BGE-300-22 embossed	BSE-300-22 embossed		

			FLOATING INTERLOCKING TAB	500 per box 33,000 per skid
	GALVANIZED	STAINLESS STEEL		<p style="text-align: center; font-size: small;">INTERLOCKING BASE REQUIRED</p>
24 Ga.	TG3-100-24	TS3-100-24		
26 Ga.	TG3-100-26	TS3-100-26 NON-STOCK ITEM		

			FLOATING SLOTTED BASE	250 per box 16,500 per skid
	GALVANIZED	STAINLESS STEEL		<p style="text-align: center; font-size: small;">SLOTTED TAB REQUIRED</p>
16 Ga.	BG-500-16	BS-500-16		
18 Ga.	BG-500-18	BS-500-18		
20 Ga.	BG-500-20	BS-500-20		
22 Ga.	BG-500-22	BS-500-22		
24 Ga.	BG-500-24	BS-500-24		

ZIMMERMAN



ALL DIMENSION ARE NOMINAL SIZES

FLOATING SLOTTED TAB			500 per box 33,000 per skid	
	GALVANIZED	STAINLESS STEEL		
24 Ga.	TG-100-24	TS-100-24		
26 Ga.	TG-100-26	TS-100-26		

SS1500 : 1-1/2" Mechanical Lock Curved

FIXED			500 per box 16,500 per skid	
	GALVANIZED	STAINLESS STEEL		
24 Ga.	FG-158-24	FS-158-24		
26 Ga.	FG-158-26	FS-158-26		

FIXED			200 per box 6,600 per skid	
	GALVANIZED	STAINLESS STEEL		
24 Ga.	FG6-158-24	FS6-158-24		
26 Ga.	FG6-158-26	FS6-158-26		

FLOATING INTERLOCKING BASE			500 per box 33,000 per skid	
	GALVANIZED	STAINLESS STEEL		
22 Ga.	BG-300-22 w/o emboss	BS-300-22 w/o emboss		
	BGE-300-22 embossed	BSE-300-22 embossed		



ALL DIMENSION ARE NOMINAL SIZES

SS1500: 1-1/2" MECHANICAL LOCK

FLOATING INTERLOCKING TAB			<i>500 per box 16,500 per skid</i>	
	GALVANIZED	STAINLESS STEEL		
24 Ga.	TG3-150-24	TS3-150-24		
26 Ga.	TG3-150-26	TS3-150-26 NON-STOCK ITEM		

FLOATING SLOTTED BASE			<i>250 per box 16,500 per skid</i>	
	GALVANIZED	STAINLESS STEEL		
16 Ga.	BG-500-16	BS-500-16		
18 Ga.	BG-500-18	BS-500-18		
20 Ga.	BG-500-20	BS-500-20		
22 Ga.	BG-500-22	BS-500-22		
24 Ga.	BG-500-24	BS-500-24		

FLOATING SLOTTED TAB			<i>500 per box 16,500 per skid</i>	
	GALVANIZED	STAINLESS STEEL		
24 Ga.	TG-150-24	TS-150-24		
26 Ga.	TG-150-26	TS-150-26		

SLC1500 : 1-1/2" Snaplock

SNAPLOCK CLIP			<i>500 per box 16,500 per skid</i>	
	GALVANIZED			
24 Ga.	SGZ2-100-24			







ZIMMERMAN

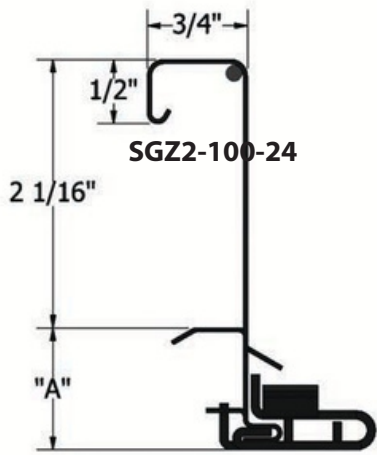

ALL DIMENSION ARE NOMINAL SIZES

SS2000 : 2" Mechanical Lock (with 90 degree leg)

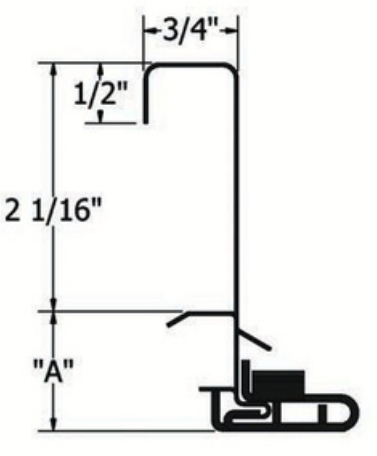
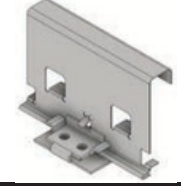
UL - FLOATING ARCHITECTURAL CLIPS

PART #	"A" DIM.			NC-XXXXX-3 STANDARD IN-STOCK BASE	
NC-33003-3 (-S)	1/2"				TAB: galvanized 22ga. BASE: galvanized 16ga. PART WIDTH: 4-1/4"
NC-33004-3 (-S)	1"				
NC-33003-6 (-S)	1/2"				TAB: galvanized 22ga. BASE: galvanized 16ga. PART WIDTH: 4-1/4"
*NC-33004-6 (-S)	1"				
QTY:				NC-XXXXX-6 OPTIONAL PURLIN STABILIZER	
110 per box 3630 per skid					
* (NC-33004-6) 100 per box 3300 per skid					
Part #	"A" DIM.			NC-XXXXX-3 STANDARD IN-STOCK BASE	
NC-33009-3 (-S)	1/2"				TAB: galvanized 22ga. BASE: galvanized 16ga. PART WIDTH: 4-1/4"
NC-33010-3 (-S)	1"				
NC-33009-6 (-S)	1/2"				TAB: galvanized 22ga. BASE: galvanized 16ga. PART WIDTH: 4-1/4"
NC-33010-6 (-S)	1"				
QTY:				NC-XXXXX-6 OPTIONAL PURLIN STABILIZER	
110 per box 3630 per skid					

UL - FIXED CLIPS

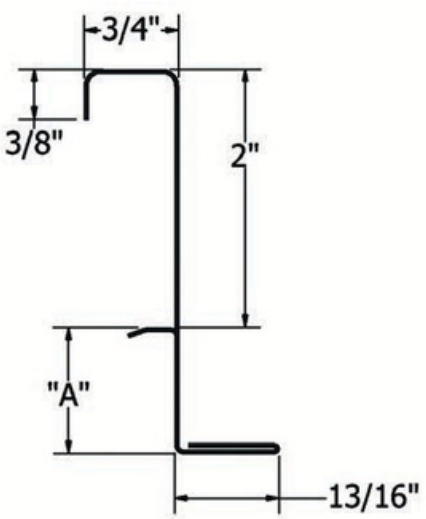
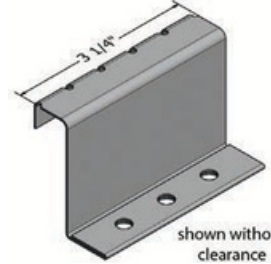
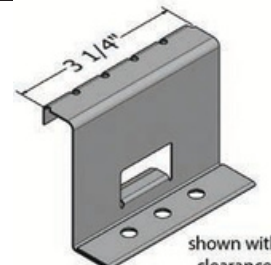
PART #	"A" DIM.			 shown without clearance	
NCF-33000 (-S)	0" CLEARANCE 3/8"			 shown with clearance	
NCF-33001 (-S)	STANDOFF 1-3/8"				
NCF-33002 (-S)	STANDOFF				
QTY:					
225 per box 7425 per skid					
22ga. galvanized					



ALL DIMENSION ARE NOMINAL SIZES

SS2000: 2" MECHANICAL LOCK (with 90 degree leg)

			FIXED		300 per box 9,900 per skid
	GALVANIZED	STAINLESS STEEL			
22 Ga.	FG-218-22	FS-218-22			
24 Ga.	FG-218-24	FS-218-24			

			FLOATING INTERLOCKING BASE		500 per box 33,000 per skid
	GALVANIZED	STAINLESS STEEL			
22 Ga.	BG-300-22 w/o emboss	BS-300-22 w/o emboss			
	BGE-300-22 embossed	BSE-300-22 embossed			

			FLOATING INTERLOCKING TAB		400 per box 13,200 per skid
	GALVANIZED	STAINLESS STEEL			
24 Ga.	TG3-200-24	TS3-200-24			
26 Ga.	TG3-200-26	TS3-200-26 NON-STOCK ITEM			

			FLOATING SLOTTED BASE		250 per box 16,500 per skid
	GALVANIZED	STAINLESS STEEL			
16 Ga.	BG-500-16	BS-500-16			
18 Ga.	BG-500-18	BS-500-18			
20 Ga.	BG-500-20	BS-500-20			
22 Ga.	BG-500-22	BS-500-22			
24 Ga.	BG-500-24	BS-500-24			

ZIMMERMAN



SS2000: 2" MECHANICAL LOCK (with 90 degree leg)

ALL DIMENSION ARE NOMINAL SIZES

FLOATING SLOTTED TAB			500 per box 16,500 per skid
	GALVANIZED	STAINLESS STEEL	
22 Ga.	TG-200-22	TS-200-22	
24 Ga.	TG-200-24	TS-200-24	

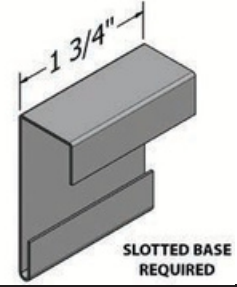

SS2000A : 2"Mechanical Lock (with 45 degree leg)

UL - FLOATING ARCHITECTURAL CLIPS

PART #	"A" DIM.		NC-XXXXX-3 STANDARD IN-STOCK BASE		
* NC-33001-3 (-S)	1/2"			TAB: galvanized 22ga. BASE: galvanized 16ga. PART WIDTH: 4-1/4"	
NC-33002-3 (-S)	1"				
NC-33001-6 (-S)	1/2"				
NC-33002-6 (-S)	1"				
QTY: *(NC-33001-3) 120 per box 3960 per skid 110 per box 3630 per skid			NC-XXXXX-6 OPTIONAL PURLIN STABILIZER		
				TAB: galvanized 22ga. BASE: galvanized 16ga. PART WIDTH: 4-1/4"	

UL - FLOATING ARCHITECTURAL CLIPS

PART #	"A" DIM.		NC-XXXXX-3 STANDARD IN-STOCK BASE		
NC-33009-3 (-S)	1/2"			TAB: galvanized 22ga. BASE: galvanized 16ga. PART WIDTH: 4-1/4"	
NC-33010-3 (-S)	1"				
NC-33009-6 (-S)	1/2"				
NC-33010-6 (-S)	1"				
QTY: 110 per box 3630 per skid			NC-XXXXX-6 OPTIONAL PURLIN STABILIZER		
				TAB: galvanized 22ga. BASE: galvanized 16ga. PART WIDTH: 4-1/4"	



ALL DIMENSION ARE NOMINAL SIZES

SS2000A: 2" MECHANICAL LOCK (with 45 degree leg)

UL - FIXED CLIPS			
PART #	"A" DIM.		
NCF-33005 (-S)	0" CLEARANCE		<p>shown without clearance</p>
NCF-33006 (-S)	1/2" STANDOFF		
NCF-33007 (-S)	1" STANDOFF		
QTY:			
225 per box 7425 per skid			
22ga. galvanized			<p>shown with clearance</p>

ZIMMERMAN

FIXED				300 per box 9,900 per skid
	GALVANIZED	STAINLESS STEEL		
22 Ga.	FG-218-22	FS-218-22		
24 Ga.	FG-218-24	FS-218-24		

FLOATING INTERLOCKING BASE				500 per box 33,000 per skid
	GALVANIZED	STAINLESS STEEL		
22 Ga.	BG-300-22 w/o emboss	BS-300-22 w/o emboss		<p>INTERLOCKING TAB REQUIRED</p>
	BGE-300-22 embossed	BSE-300-22 embossed		



SS2000A: 2" MECHANICAL LOCK (with 45 degree leg)

ALL DIMENSION ARE NOMINAL SIZES

FLOATING INTERLOCKING TAB			<i>400 per box 13,200 per skid</i>
	GALVANIZED	STAINLESS STEEL	
24 Ga.	TG3-200-24	TS3-200-24	
26 Ga.	TG3-200-26	TS3-200-26 NON-STOCK ITEM	

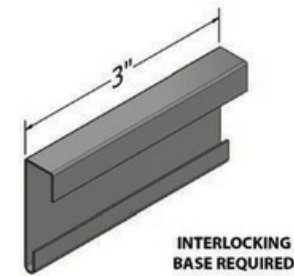

FLOATING SLOTTED TAB			<i>500 per box 16,500 per skid</i>
	GALVANIZED	STAINLESS STEEL	
22 Ga.	TG-200-22	TS-200-22	
24 Ga.	TG-200-24	TS-200-24	

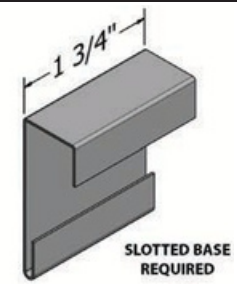

FLOATING SLOTTED BASE			<i>250 per box 16,500 per skid</i>
	GALVANIZED	STAINLESS STEEL	
16 Ga.	BG-500-16	BS-500-16	
18 Ga.	BG-500-18	BS-500-18	
20 Ga.	BG-500-20	BS-500-20	
22 Ga.	BG-500-22	BS-500-22	
24 Ga.	BG-500-24	BS-500-24	

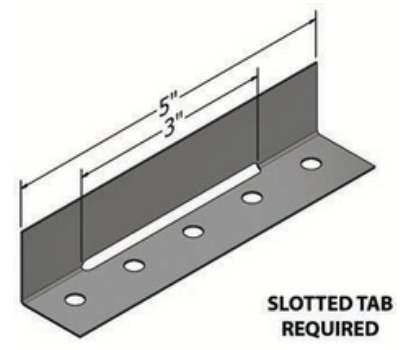

ZIMMERMAN



ALL DIMENSION ARE NOMINAL SIZES

SS2500: 2-1/2" Mechanical Lock

FIXED CLIPS 300 per box 9900 per skid

	GALVANIZED	STAINLESS STEEL		
22 Ga.	FG-258-22	FS-258-22		
24 Ga.	FG-258-24	FS-258-24		

FLOATING INTERLOCKING BASE 500 per box 33,000 per skid

	GALVANIZED	STAINLESS STEEL		
22 Ga.	BG-300-22 w/o emboss	BS-300-22 w/o emboss		
	BGE-300-22 embossed	BSE-300-22 embossed		

FLOATING INTERLOCKING TAB 400 per box 13,200 per skid

	GALVANIZED	STAINLESS STEEL		
24 Ga.	TG3-250-24	TS3-250-24		
26 Ga.	TG3-250-26	TS3-250-26 NON-STOCK ITEM		

FLOATING SLOTTED TAB 500 per box 16,500 per skid

	GALVANIZED	STAINLESS STEEL		
22 Ga.	TG-250-22	TS-250-22		
24 Ga.	TG-250-24	TS-250-24		

ZIMMERMAN



SS2500: 2-1/2" MECHANICAL LOCK

ALL DIMENSION ARE NOMINAL SIZES

FLOATING SLOTTED BASE			250 per box 16,500 per skid	
	GALVANIZED	STAINLESS STEEL		
16 Ga.	BG-500-16	BS-500-16		
18 Ga.	BG-500-18	BS-500-18		
20 Ga.	BG-500-20	BS-500-20		
22 Ga.	BG-500-22	BS-500-22		
24 Ga.	BG-500-24	BS-500-24		

ZIMMERMAN

TSS-3000A & TSS-3000B

PART #		QTY:	UL - FLOATING TRAPEZOIDAL CLIPS	
NC-34526-3-S		130 per box 4290 per skid		NC-XXXXX-3 STANDARD IN-STOCK BASE
NC-34526-6-S		100 per box 3300 per skid		<p>TAB: galvanized 22ga. BASE: galvanized 16ga. PART WIDTH: 4-1/4"</p>
				NC-XXXXX-6 OPTIONAL PURLIN STABILIZER
				<p>TAB: galvanized 22ga. BASE: galvanized 16ga. PART WIDTH: 4-1/4"</p>

PART NUMBER		"A"	FLOATING TRAPEZOIDAL CLIPS		
NC-34502-3 (-S)		3-1/4"			
NC-34502-6 (-S)		3-1/4"			
Tab: 22ga. G90 Galvanized Base: 16 ga. Galvanized Factory Applied Sealant Optional					



ALL DIMENSIONS ARE NOMINAL SIZES

TS3000: 3" MECHANICAL LOCK

TS3000 : Engineered Panel Closures

OUTSIDE CLOSURE			<i>N/A per box N/A per skid</i>	
	MATERIAL NO.	DESCRIPTION		
24 Ga.	ZOC-12	Inside closure 24 ga. AZ/Galvalume		<p>Specifications Height: 2.88" Width: 1.36" Holes: 11</p>
24 Ga.	ZOC-18	Inside closure 24 ga. AZ/Galvalume		
24 Ga.	ZOC-24	Inside closure 24 ga. AZ/Galvalume		

Compatible with: Zimmerman TS-3000 Panel

INSIDE CLOSURE			<i>N/A per box N/A per skid</i>	
	MATERIAL NO.	DESCRIPTION		
18 Ga.	ZIC-001	Inside closure 18 ga. AZ/Galvalume		<p>Specifications Height: 1-3/4" Width: 4-1/4" Holes: 2</p>

Compatible with: Zimmerman TS-3000 Panel

ZIMMERMAN



HIGH CAPACITY RAKE & EAVE PLATES

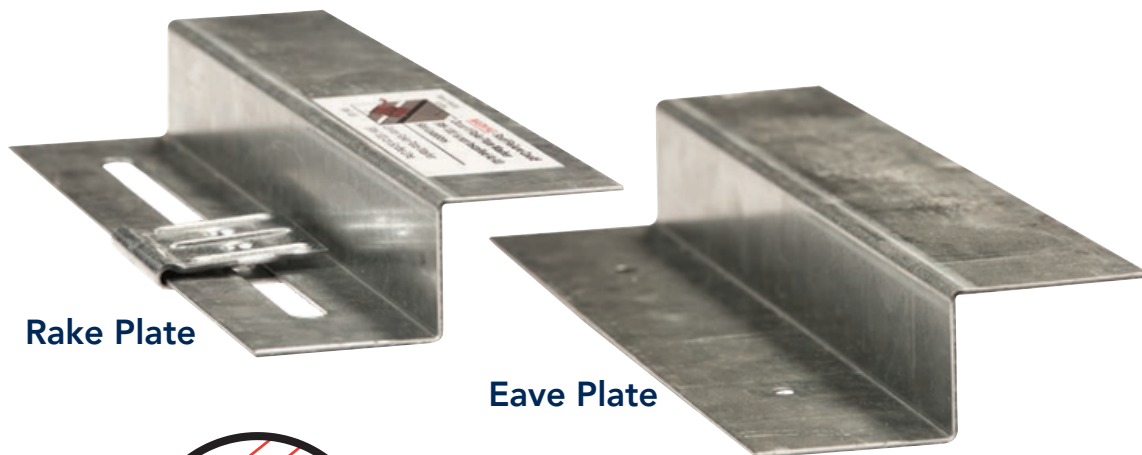

Rake Plate

Eave Plate



DESIGNING FOR TOMORROW'S CODES - TODAY

The Design and Engineering group at Building Research Systems, Inc. has come to represent forward thinking through continuing improvements and innovations of premier metal standing seam roofing systems and accessories. Their incessant desire to improve the industry's standing seam roof systems has led to yet another benchmark performance enhancement with the innovation of the patented High Capacity Rake and Eave plates. These patented designed components were engineered in part due to the upcoming more stringent ASCE 7 edge /corner zone uplift requirements for all metal standing seam roof systems. These high performance parts were also developed with the new MBC/MBMA inspired edge metal testing protocol in mind coupled with the need for a longer travel slide to match the roof clips capabilities for thermal expansion and contraction. These patented revolutionary parts provide a standing seam roofing system critical edge/corner zone uplift capabilities that out performs all other systems currently on the market today.

Benefits at a Glance

1. High Capacity Rake and Eave Plate designs for the critical edge/corner zones tested to be significantly stronger than the current designs in service. However, the new patented parts only lose serviceability performance (movement for thermal expansion) due to the unique design of the retainer parts clamping design which allows the roof to remain intact preventing possible catastrophic roof loss.
2. The variety of vertical web depth availability of the new parts work with the standing seam industry standard clip heights of 1/2", 1", 1-1/2" and 2" as well as the taller standoff clip heights of 2-1/2" and 3". Custom heights are available. The parts designs work with new or retrofit roof applications that utilize the taller standoff clips in their construction design.
3. High Capacity Rake/Eave plate parts are formed using 16 -gauge G-90 galvanized steel construction for durability and maximum performance for panel and/or trim attachments.
4. Extended horizontal 2" top/bottom leg flanges on both the rake and eave plate parts provide an ample stable attachment contact surface for the installer assuring a weather-tight seal along with superior uplift performance when installed correctly with the proper sealants and fasteners. This allows individual panel manufacturers freedom for their specific or unique trim design.

HIGH CAPACITY RAKE & EAVE PLATES

Benefits at a Glance continued

5. Pre-punched High Capacity Rake plates have 3/8" X 8-1/4" slots on 18" centers down the 10'-0" length of the part. These slots allow quick attachment using seven (7) factory installed rake plate retainer parts using two 1/4-14 fasteners per retainer to the sub-structure. The RP retainer parts are field aligned during installation with the scribed vertical leg guide lines which indicates the center point of each slot for proper attachment.
6. An instructional decal is permanently adhered to one end of the rake part for field installation directions, assuring the installer proper procedures for correct RP retainer part location/attachment.
7. The unique slot/retainer part design of the High Capacity Rake plate allows for maximum thermal expansion contraction for up to 7" overall slide travel.
8. All High Capacity Eave plates are pre-punched with 1/4" round fastener attachment holes at 6" on center down the full length of the part. The pre-punched round holes aid in the installation of the 16-gauge galvanized part for simplification of install and proper fastener location. These pre-punched holes assure all parties maximum uplift performance when the correct fasteners are properly installed during erection.
9. All parts are supplied in convenient ten foot (10'-0) lengths for ease of jobsite handling and quicker field installations.
10. The part designs are independent laboratory third party tested for performance with assigned design values. The forward thinking design will meet or exceed the more stringent anticipated ASCE 7 corner/ edge zone uplift loads for all metal standing seam roof systems that will shortly be imposed. The part testing also assures that it will not be the weak link in the upcoming MCA/MBMA inspired edge metal test protocol.
11. Supports architects, specification writers, and owners' requirements for thicker fiberglass blanket insulation systems for ever increasing green design higher "R" and lower "U" values mandated code needs.
12. The need for dual attachment fastener type inventory will be eliminated since the high capacity rake/eave plate design uses the same 1/4-14 screws (no shoulder fasteners required) for connecting to the structural support system. The elimination of shoulder fasteners removes the possibility of an improper install in the wrong location.
13. The eave plate pre-punched holes, as well as the factory pre-assembled rake, with the retainer parts placed into the slots make for a quicker installation and an erector friendly experience for proper fastener placement.
14. The unique patented design provides more stiffness for the standing seam roof diaphragm during testing.





The design and engineering of these parts meet the need for tomorrow's more stringent corner/edge zones uplift codes, TODAY. Contact BPD today for the highest performing patented High Capacity Rake/Eave plate technology available within the industry.

Hc Rake & Eave Plates

ALL DIMENSION ARE NOMINAL SIZES

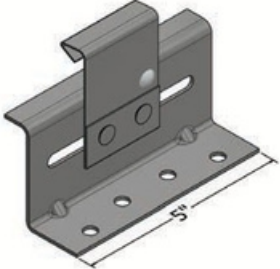
BPD, Inc.

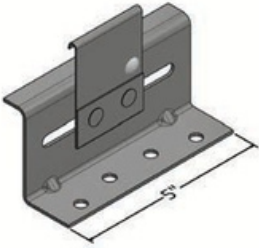
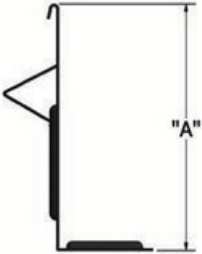
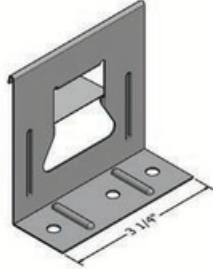
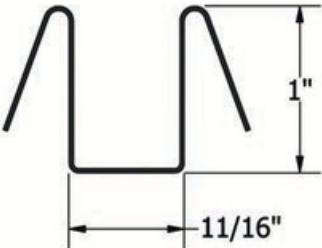
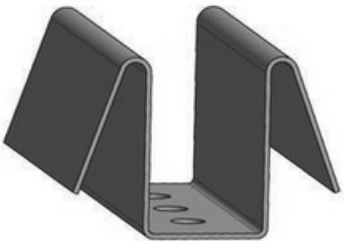
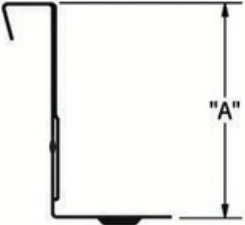
MISCELLANEOUS

PART NUMBER	A DIM.		
BW-2122	2-1/2"		
BW-2124	3-1/2"		
PART NUMBER	A DIM.		
BW-2102	2-1/2"		
BW-2104	3-1/2"		
PART NUMBER	A DIM.		
BW-200	3"		
BW-204	3.25"		
BW-208	4.25"		
ED - 0062			
24 ga. G-90 Galvanized Steel			
BUTTERFLY	A DIM.		
NB-150	1-1/2"		
NB-100	1"		

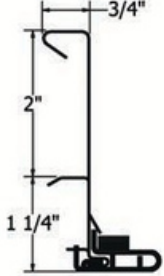
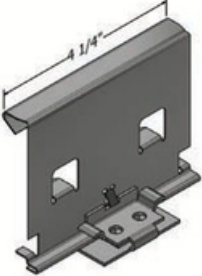
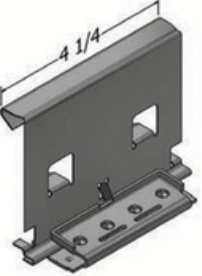

ALL DIMENSION ARE NOMINAL SIZES

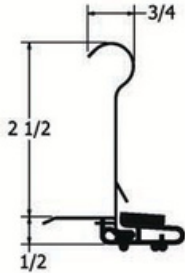
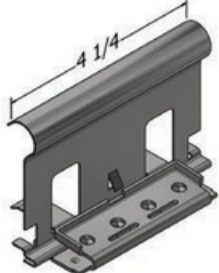
<p>NC-33015-3(-S) & NC-33015-6(-S)</p>				
<p>Tab: 22ga. G90 Galvanized Base: 16ga. Galvanized FactoryAppliedSealantOptional</p>				

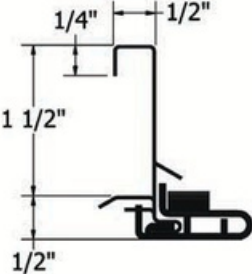
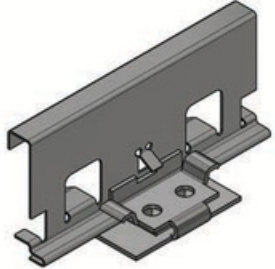
<p>NC-33017-6 & NC-33017-6-SS</p>		
<p>Tab: 22ga. G90 Galvanized & 22ga Stainless Steel Base: 16 ga.Galvanized</p>		

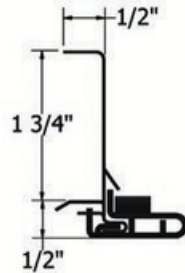
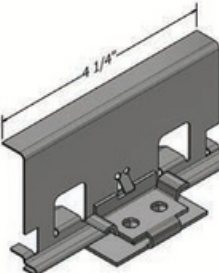
<p>NC-33018-TTS</p>		
<p>Tab: 22ga. Stainless Steel Base: 16ga. Galvanized Factory Applied Sealant Optional</p>		

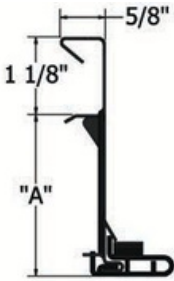
<p>NC-33025-3 & NC-33025-3-SS</p>		
<p>Tab: 22ga. G90 Galvanized & 22ga. Stainless Steel Base: 16 ga. Galvanized Factory Applied Sealant Optional</p>		

PART NUMBER	"A"			
NC-34500-3 (-S)	2"			
NC-34500-6 (-S)	2"			
NC-34501-3 (-S)	2-1/4"			
NC-34501-6 (-S)	2-1/4"			
NC-34502-3 (-S)	3-1/4"			
NC-34502-6 (-S)	3-1/4"			
<p>Tab: 22ga. G90 Galvanized Base: 16 ga. Galvanized Factory Applied Sealant Optional</p>				

ALL DIMENSION ARE NOMINAL SIZES

PART NUMBER	"A"		
NC-34508-3 (-S)	1-3/4"		
NC-34509-3 (-S)	2-1/8"		
NC-34510-3 (-S)	2-3/4"		
NC-34511-3 (-S)	3-1/8"		
Tab: 22ga. G90 Galvanized Base: 16 ga. Galvanized Factory Applied Sealant Optional			

PART NUMBER	"A"		
NC-34521-3 (-S)	1-7/8"		
NC--34522-3 (-S)	2-7/8"		
Tab: 22ga. G90 Galvanized Base: 16ga. Galvanized Factory Applied Sealant Optional			

PART NUMBER	"A"		
NC-34523-3 (-S)	1-5/8"		
NC-34524-3 (-S)	2-5/8"		
Tab: 22ga. G90 Galvanized Base: 16ga. Galvanized Factory Applied Sealant Optional			

PART NUMBER		"A"		
BCG-100-24	24 ga.	7/8"		
BCG-100-26	26 ga	7/8"		
BCG-075-24	24 ga	5/8"		
BCG-075-26	26 ga	5/8"		
Available in galvanized and stainless steel. Call for pricing! (866) 766-3254				

ALL DIMENSION ARE NOMINAL SIZES

TILE CLIPS SS			
26 ga. Stainless Steel			

BERMUDA CLIPS			
FGB-187-24	24 ga.		
FSB-187-24	24 ga.		
FGB-187-26	26 ga		
FSB-187-26	26 ga.		

BERMUDA CLIPS			
FGB-200-24	24 ga.		
FSB-200-24	24 ga.		
FGB-200-26	26 ga		
FSB-200-26	26 ga.		

PART NUMBER	"A"	"B"			
C401(S)	1"	1"			
C402(S)	1"	2-1/4"			
C403(S)	1"	3-1/4"			
C451(S)	7/8"	1"			
C452(S)	7/8"	2-1/4"			
C453(S)	7/8"	3-1/4"			
TAB: 20 ga. 50 ksi galvalume/galvanized BASE: 24 ga. g-90 galvalume/ galvalume Factory Applied Sealant Optional					

BPD, Inc. ACCESSORIES

ALL DIMENSION ARE NOMINAL SIZES

GUTTER HANGER	
PART #	"A" DIM.
GH-5	5"
GH-6	6"
GH-7	7"
GH-8	8"
16 ga. Galvanized Steel	

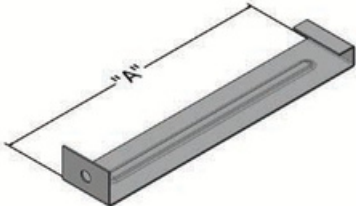

UNIVERSAL BEARING PLATE
BPG-4X5-16-1-2S 16 ga. Galvanized
Visit wegotclips.com for other available bearing plates

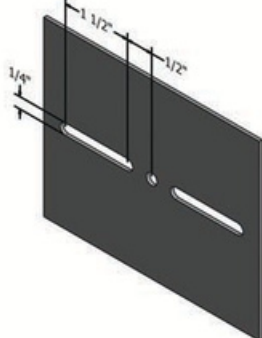

GUTTER SUPPORT NORTHERN
CC 602 G-90 Galvanized 50ksi

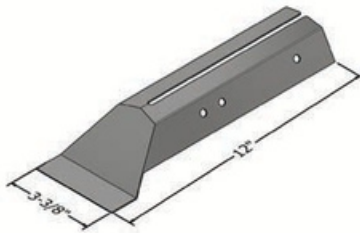

BACK-UP PLATE
BP 324 16 ga. Galvanized

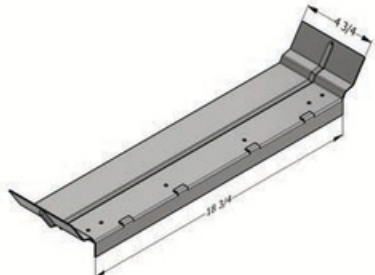

GUTTER SUPPORT SOUTHERN
CC 601 G-90 Galvanized 50ksi

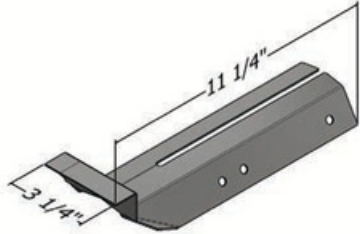

INSIDE CLOSURE
CC 324 24 ga. Galvanized
CC 324 - 18 18 ga. Galvalume

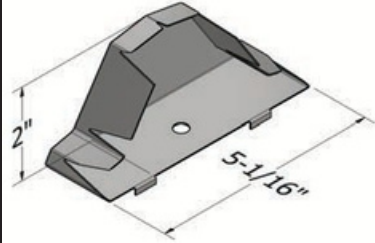

48\" ENDLAP BACK-UP CHANNEL
BP 148 16 ga. Galvanized Steel

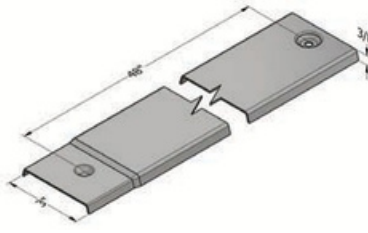

72\" ENDLAP BACK-UP CHANNEL
BP 172 16 ga. Galvanized Steel

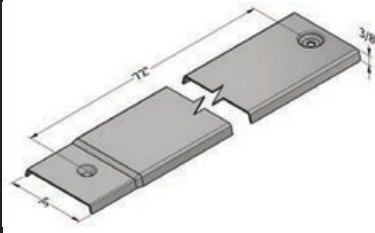

ALL DIMENSION ARE NOMINAL SIZES

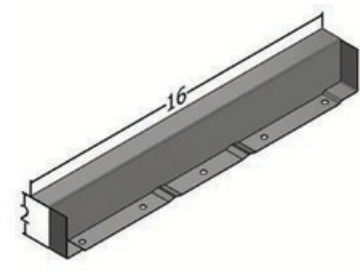
OUTSIDE CLOSURE	
FED 216 24 ga. Galvanized Steel	

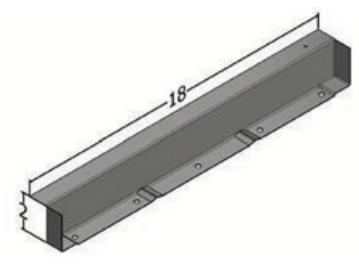
OUTSIDE CLOSURE	
FED 218 24 ga. Galvanized Steel	

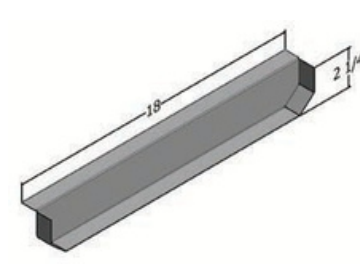
END DAM	
ED-TRQ250 24 ga. Galvalume	

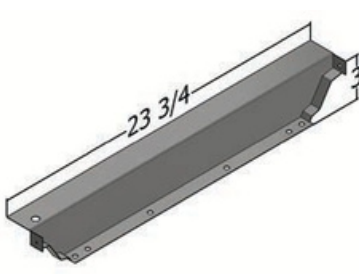
END DAM	
ED 324 24 ga., Zinalume, Galvanized (5oz coating)	

16" ENDLAP CINCH PLATE	
CS 116 20 ga. Stainless Steel	

18" ENDLAP CINCH PLATE	
CS 118 20 ga. Stainless Steel	

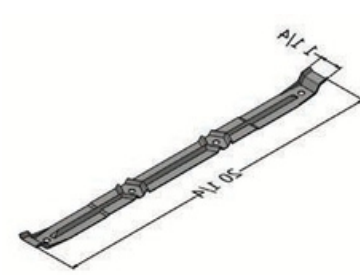
CINCH STRAP	
CS 324 20 ga. Stainless Steel	

ALL DIMENSION ARE NOMINAL SIZES

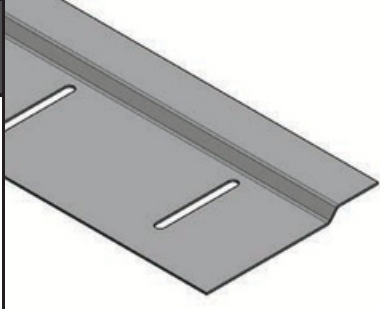
PERIMETER PLATE LOW	
PP038 16 ga. Galvanized Steel	

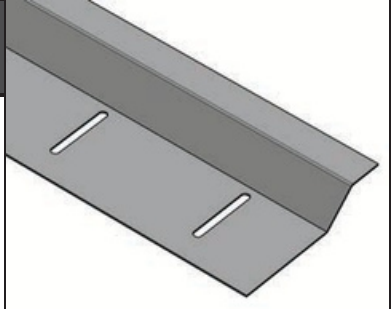
PERIMETER PLATE HIGH	
PP138 16 ga. Galvanized Steel	

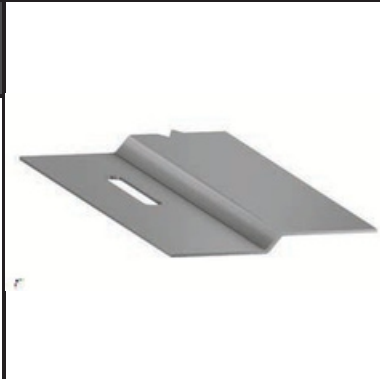
PERIMETER PLATE- LOW	
RP 038 16 ga. Galvanized Steel	

PERIMETER PLATE- HIGH	
RP 138 16 ga. Galvanized Steel	

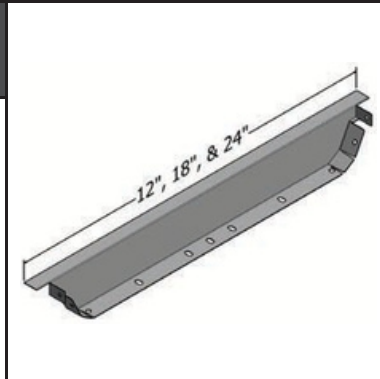
OUTSIDE CLOSURE	
BW-430 24 ga. Galvanized Steel	

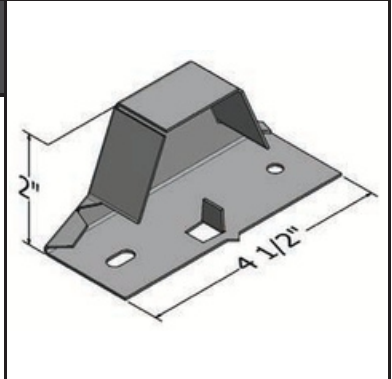
INSIDE CLOSURE	
BW-426 18 ga. Galvanized Steel	



(800) 771-1711

sales@roofhugger.com

www.roofhugger.com

RETROFIT PRODUCTS

MODEL "C"

This part is 1.83" tall and designed to accommodate existing ribbed metal roofing panels with 1-1/2" or less major ribs spaced at 12" on center.

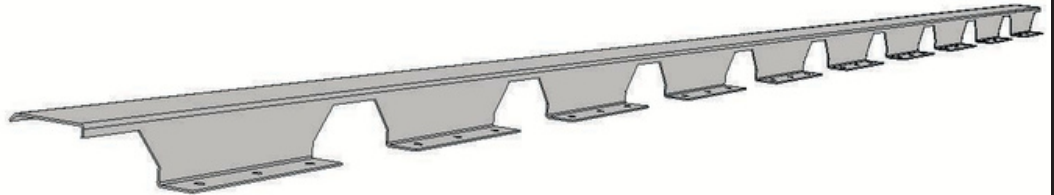

MODEL "D"

This part is 4.5" tall and designed to accommodate existing 24" o.c. Trapezoidal SSR metal roof panels that do not have tall clips and thermal spacers.

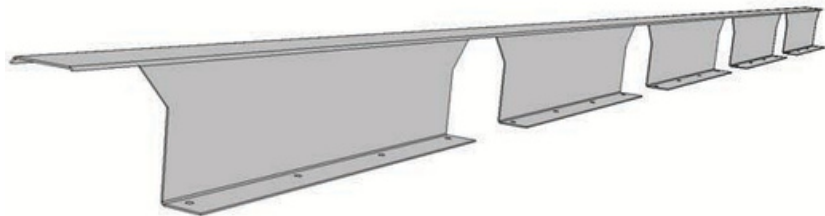

MODEL "T"

This part is 4.5" tall and designed with a patented anti-rotational arm to accommodate existing 24" o.c. Trapezoidal SSR metal roof panels that are installed with tall clips and/or thermal spacers.

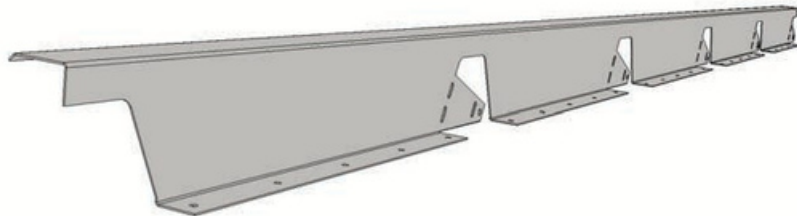

CUSTOM HUGGERS

This term refers to ROOF HUGGER Sub-Purlins that are produced to a non-standard panel profile or height to accommodate the project needs.

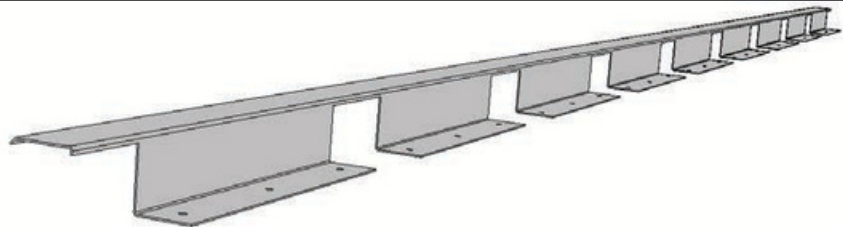

CORRU-FIT[®] HUGGERS

This system is a 2.75" total height 2 piece assembly consisting of a 1.25" or 1.625" spacer mounted under a 1.625" or 1.125" respective Zee, with slots in the base flange specifically designed for corrugated roofs.

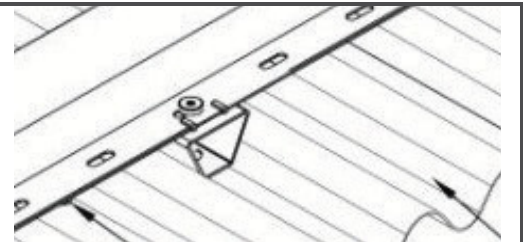

Structural Hat Sections

- Five sizes to choose from
- Lengths available from 6ft. to 21 ft.
- All have 2" wide top flanges
- All hats are 16ga. 50 KSI A653 SS grade steel
- all are roll-formed from g90 pre-galvanized coil

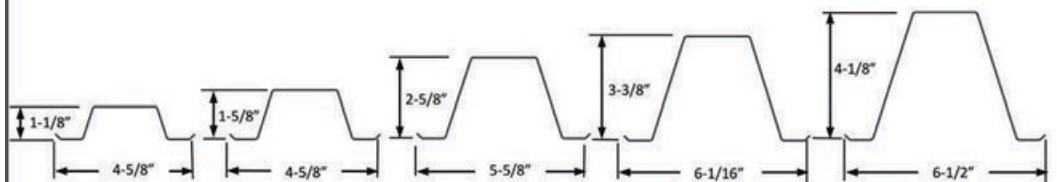

Are you a **Contractor**
looking for **Clips & Accessories**



(866) 766-3254
wegotclips.com

BPD supplies contractors with clips and accessories for the following roof systems: New Tech, Englert, Ultra Seam, Zimmerman, Knudson, Rollformer, Schleich, Quadra-Pro™ & more!



Are you looking for **Retrofit**
Metal Roof Systems



(800) 771-1711
RoofHugger.com

Roof Hugger supplies any industry with factory-notched sub-purlin systems for all standing seam panel systems, thru-fastened roofs and corrugated. Don't replace your roof - retrofit it with Roof Hugger!



Are you a **Manufacturer**
looking for **Clips & Accessories**



(574) 722-3101
LoganStampings.com

Logan Stampings supplies metal building and metal roof manufactures with clips and accessories!

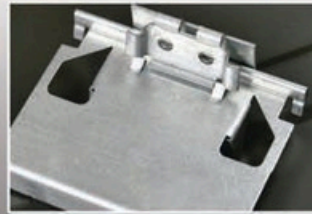
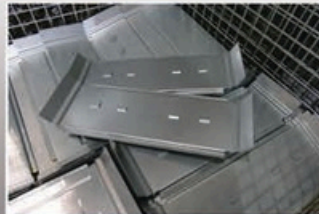

All under one roof!

Logan Stampings - BPD - Roof Hugger





MEMBERS OF



WEGOTCLIPS.COM | (866) 766-3254