



**BUILDING PRODUCTS DEVELOPMENT**  
**STANDING SEAM CLIPS**  
**& ACCESSORIES**

**WEGOTCLIPS.COM | (866) 766-3254**

*MORE THAN A CLIP SUPPLIER, BPD HAS BECOME THE INDUSTRY DESIGN COMPANY FOR IMPROVING OVERALL PERFORMANCE.*



### **Welcome to Building Products Development, Inc.**

Since inception, Building Products Development, Inc. (BPD) has focused on developing and producing state-of-the-art products for the metal construction industry. Our resources and expertise have allowed us to develop standing seam clips with exceptional performance that can easily be adapted to fit almost any standing seam profile.

### **More than a clip provider**

We offer specialized services including clip development, technical and product applications. BPD boasts over 40 years experience in the metal construction industry, providing a unique advantage over other clip providers. Our professionals are experienced in all facets of the industry including roof design, testing, and fabrication. Our specialized services coupled with our extensive knowledge, offer our customers unparalleled support.

### **Commitment to Quality**

The manufacturing facility producing these clips is ISO9001 Certified which assures you of regular audits on both material and workmanship. Clips are never made with material seconds or coil leftovers. When you buy from us, you are always getting ASTM specified prime steel.

### **Testing**

BPD has established solid relationships with the leaders of the metal roofing industry enabling us to provide testing and support to all of our customers. We work with a certified independent testing laboratory, as well as our own in house laboratory to conduct many different tests. We can provide pull tests and ASTM tests, standing water tests, ASTM 1592 tests and air and water infiltration. Reports can be purchased through BPD, please call to discuss testing in detail.

### **Stamping Needs**

BPD has developed unique tooling that can be economically modified to match your panel needs. If you do not find a clip in this catalog that fits, we may be able to develop and design a custom clip for you. More than clips, we also provide roof accessories and other stamped parts. If you have an idea for a new product, our design team would be happy to provide a quote to you.

### **Advantages of using BPD clips:**

- Full line of standard clips
- Large selection stocked and ready for immediate delivery
- Many clips are UL listed
- Best overall clip value in the industry
- Custom clip and component design
- Design assistance to improve existing components
- No charge, fast prototyping
- We pay tooling costs for qualified customers
- Full performance testing available: UL, ASTM E1592, E1646, E1680

# NEWTECH

## SS100 : 1" MECHANICAL LOCK

### FIXED CLIPS

1,000 per box  
33,000 per skid

	GALVANIZED	STAINLESS STEEL		
24 Ga.	<b>FG-100-24</b>	<b>FS-100-24</b>		
26 Ga.	<b>FG-100-26</b>	<b>FS-100-26</b>		

### FLOATING INTERLOCKING BASE

500 per box  
33,000 per skid

	GALVANIZED	STAINLESS STEEL		
22 Ga.	<b>BG-300-22</b> w/o emboss	<b>BS-300-22</b> w/o emboss		<p>INTERLOCKING TAB REQUIRED</p>
22 Ga.	<b>BGE-300-22</b> embossed	<b>BSE-300-22</b> embossed		

### FLOATING INTERLOCKING TAB

500 per box  
33,000 per skid

	GALVANIZED	STAINLESS STEEL		
24 Ga.	<b>TG3-100-24</b>	<b>TS3-100-24</b>		<p>INTERLOCKING BASE REQUIRED</p>
26 Ga.	<b>TG3-100-26</b>	<b>TS3-100-26</b>		

### FLOATING SLOTTED TAB

500 per box  
33,000 per skid

	GALVANIZED	STAINLESS STEEL		
24 Ga.	<b>TG-100-24</b>	<b>TS-100-24</b>		<p>SLOTTED BASE REQUIRED</p>
26 Ga.	<b>TG-100-26</b>	<b>TS-100-26</b>		

ALL DIMENSION ARE NOMINAL SIZES

## SS100: 1" MECHANICAL LOCK

### FLOATING SLOTTED BASE

250 per box  
16,500 per skid

	GALVANIZED	STAINLESS STEEL		
16Ga.	<b>BG-500-16</b>	<b>BS-500-16</b>		<p>SLOTTED TAB REQUIRED</p>
18 Ga.	<b>BG-500-18</b>	<b>BS-500-18</b>		
20 Ga.	<b>BG-500-20</b>	<b>BS-500-20</b>		
22 Ga.	<b>BG-500-22</b>	<b>BS-500-22</b>		
24 Ga.	<b>BG-500-24</b>	<b>BS-500-24</b>		

## SS150 : 1-1/2" MECHANICAL LOCK

### UL - FLOATING ARCHITECTURAL CLIPS

PART #	QTY:		
NC-33018-3 (-S)	130 per box 4290 per skid		NC-XXXXX-3   <b>STANDARD IN-STOCK BASE</b>
NC-33018-6 (-S)			<p>TAB: galvanized 22ga. BASE: galvanized 16ga. PART WIDTH: 4-1/4"</p>
			NC-XXXXX-6   <b>OPTIONAL PURLIN STABILIZER</b>
			<p>TAB: galvanized 22ga. BASE: galvanized 16ga. PART WIDTH: 4-1/4"</p>

### FLOATING INTERLOCKING TAB

400 per box  
13,200 per skid

	GALVANIZED	STAINLESS STEEL		
24 Ga.	<b>TG3-150-24</b>	<b>TS3-150-24</b>		<p>INTERLOCKING BASE REQUIRED</p>
26 Ga.	<b>TG3-150-26</b>	<b>TS3-150-26</b> NON-STOCK ITEM		

SS150: 1-1/2" MECHANICAL LOCK

ALL DIMENSION ARE NOMINAL SIZES

FLOATING INTERLOCKING BASE			500 per box 33,000 per skid	
	GALVANIZED	STAINLESS STEEL		
22 Ga.	BG-300-22 w/o emboss	BS-300-22 w/o emboss		INTERLOCKING TAB REQUIRED
22 Ga.	BGE-300-22 embossed	BSE-300-22 embossed		

FIXED CLIPS				
	GALVANIZED	STAINLESS STEEL		
24 Ga.	FG-158-24	FS-158-24		500 per box 16,500 per skid
26 Ga.	FG-158-26	FS-158-26		
24 Ga.	FG6-158-24	FS6-158-24		
26 Ga.	FG6-158-26	FS6-158-26		200 per box 6,600 per skid

FLOATING SLOTTED BASE			250 per box 16,500 per skid	
	GALVANIZED	STAINLESS STEEL		
16 Ga.	BG-500-16	BS-500-16		SLOTTED TAB REQUIRED
18 Ga.	BG-500-18	BS-500-18		
20 Ga.	BG-500-20	BS-500-20		
22 Ga.	BG-500-22	BS-500-22		
24 Ga.	BG-500-24	BS-500-24		

ALL DIMENSION ARE NOMINAL SIZES

SS150: 1-1/2" MECHANICAL LOCK

FLOATING SLOTTED TAB			500 per box 16,500 per skid	
	GALVANIZED	STAINLESS STEEL		
24 Ga.	TG-150-24	TS-150-24		SLOTTED BASE REQUIRED
26 Ga.	TG-150-26	TS-150-26		

SS200 : 2" MECHANICAL LOCK

UL - FLOATING ARCHITECTURAL CLIPS			
PART #	"A" DIM.		NC-XXXXX-3   STANDARD IN-STOCK BASE
* NC-33001-3 (-S)	1/2"		
NC-33002-3 (-S)	1"		
NC-33001-6 (-S)	1/2"		
NC-33002-6 (-S)	1"		
<b>QTY:</b>			NC-XXXXX-6   OPTIONAL PURLIN STABILIZER
* (NC-33001-3) 120 per box 3960 per skid			<b>TAB:</b> galvanized 22ga. <b>BASE:</b> galvanized 16ga. <b>PART WIDTH:</b> 4-1/4"
110 per box 3630 per skid			

UL - FLOATING ARCHITECTURAL CLIPS			
PART #	"A" DIM.		NC-XXXXX-3   STANDARD IN-STOCK BASE
NC-33009-3 (-S)	1/2"		
NC-33010-3 (-S)	1"		
NC-33009-6 (-S)	1/2"		
NC-33010-6 (-S)	1"		
<b>QTY:</b>			NC-XXXXX-6   OPTIONAL PURLIN STABILIZER
110 per box 3630 per skid			<b>TAB:</b> galvanized 22ga. <b>BASE:</b> galvanized 16ga. <b>PART WIDTH:</b> 4-1/4"

NEWTECH

NEWTECH

SS200: 2" MECHANICAL LOCK

ALL DIMENSION ARE NOMINAL SIZES

**UL - FIXED CLIPS**

PART #	"A" DIM.		
NCF-33005 (-S)	0" CLEARANCE		<p>shown without clearance</p>
NCF-33006 (-S)	1/2" STANDOFF		
NCF-33007 (-S)	1" STANDOFF		
<b>QTY:</b>			<p>shown with clearance</p>
225 per box 7425 per skid			
22 ga. galvanized			

**FIXED CLIPS** 300 per box  
9,900 per skid

	GALVANIZED	STAINLESS STEEL		
22 Ga.	FG-218-22	FS-218-22		
24 Ga.	FG-218-24	FS-218-24		

**FLOATING SLOTTED TAB** 500 per box  
16,500 per skid

	GALVANIZED	STAINLESS STEEL		
22 Ga.	TG-200-22	TS-200-22		<p>SLOTTED BASE REQUIRED</p>
24 Ga.	TG-200-24	TS-200-24		

ALL DIMENSION ARE NOMINAL SIZES

SS200: 2" MECHANICAL LOCK

**FLOATING SLOTTED BASE** 250 per box  
16,500 per skid

	GALVANIZED	STAINLESS STEEL		
16 Ga.	BG-500-16	BS-500-16		<p>SLOTTED TAB REQUIRED</p>
18 Ga.	BG-500-18	BS-500-18		
20 Ga.	BG-500-20	BS-500-20		
22 Ga.	BG-500-22	BS-500-22		
24 Ga.	BG-500-24	BS-500-24		

**FLOATING INTERLOCKING TAB** 400 per box  
13,200 per skid

	GALVANIZED	STAINLESS STEEL		
24 Ga.	TG3-200-24	TS3-200-24		<p>INTERLOCKING BASE REQUIRED</p>
26 Ga.	TG3-200-26	TS3-200-26		

**FLOATING INTERLOCKING BASE** 500 per box  
33,000 per skid

	GALVANIZED	STAINLESS STEEL		
22 Ga.	BG-300-22 w/o emboss	BS-300-22 w/o emboss		<p>INTERLOCKING TAB REQUIRED</p>
22 Ga.	BGE-300-22 embossed	BSE-300-22 embossed		

NEWTECH

NEWTECH

ALL DIMENSION ARE NOMINAL SIZES

**SS210 : 2" MECHANICAL LOCK**  
(with additional leg on male)

UL - FLOATING ARCHITECTURAL CLIPS			
PART #	"A" DIM.		NC-XXXXX-3   STANDARD IN-STOCK BASE
NC-33003-3 (-S)	1/2"		
NC-33004-3 (-S)	1"	<p>NC-XXXXX-6   OPTIONAL PURLIN STABILIZER</p> <p><b>TAB:</b> galvanized 22ga. <b>BASE:</b> galvanized 16ga. <b>PART WIDTH:</b> 4-1/4"</p>	
NC-33003-6 (-S)	1/2"		
* NC-33004-6 (-S)	1"	<p>NC-XXXXX-6   OPTIONAL PURLIN STABILIZER</p> <p><b>TAB:</b> galvanized 22ga. <b>BASE:</b> galvanized 16ga. <b>PART WIDTH:</b> 4-1/4"</p>	
<b>QTY:</b>			
110 per box 3630 per skid			
* (NC-33004-6)			
100 per box 3300 per skid			
PART #	"A" DIM.		NC-XXXXX-3   STANDARD IN-STOCK BASE
NC-33009-3 (-S)	1/2"		
NC-33010-3 (-S)	1"	<p>NC-XXXXX-6   OPTIONAL PURLIN STABILIZER</p> <p><b>TAB:</b> galvanized 22ga. <b>BASE:</b> galvanized 16ga. <b>PART WIDTH:</b> 4-1/4"</p>	
NC-33009-6 (-S)	1/2"		
NC-33010-6 (-S)	1"	<p>NC-XXXXX-6   OPTIONAL PURLIN STABILIZER</p> <p><b>TAB:</b> galvanized 22ga. <b>BASE:</b> galvanized 16ga. <b>PART WIDTH:</b> 4-1/4"</p>	
<b>QTY:</b>			
110 per box 3630 per skid			

UL - FIXED CLIPS				
PART #	"A" DIM.			
NCF-33000 (-S)	0" CLEARANCE			
NCF-33001 (-S)	3/8" STANDOFF	<p>shown without clearance</p>		
NCF-33002 (-S)	1-3/8" STANDOFF		<p>shown with clearance</p>	
<b>QTY:</b>				
225 per box 7425 per skid				
22ga. galvanized				

ALL DIMENSION ARE NOMINAL SIZES

**SS210: 2" MECHANICAL LOCK** (with additional leg on male)

FIXED CLIPS			300 per box 9,900 per skid			
	GALVANIZED	STAINLESS STEEL				
22 Ga.	FG-218-22	FS-218-22				
24 Ga.	FG-218-24	FS-218-24				

FLOATING INTERLOCKING TAB			400 per box 13,200 per skid			
	GALVANIZED	STAINLESS STEEL		<p>INTERLOCKING BASE REQUIRED</p>		
24 Ga.	TG3-200-24	TS3-200-24				
26 Ga.	TG3-200-26	TS3-200-26 NON-STOCK ITEM				

FLOATING INTERLOCKING BASE			500 per box 33,000 per skid			
	GALVANIZED	STAINLESS STEEL		<p>INTERLOCKING TAB REQUIRED</p>		
22 Ga.	BG-300-22 w/o emboss	BS-300-22 w/o emboss				
22 Ga.	BGE-300-22 embossed	BSE-300-22 embossed				

FLOATING SLOTTED TAB			500 per box 16,500 per skid			
	GALVANIZED	STAINLESS STEEL		<p>SLOTTED BASE REQUIRED</p>		
22 Ga.	TG-200-22	TS-200-22				
24 Ga.	TG-200-24	TS-200-24				

NEWTECH

NEWTECH

**SS210: 2" MECHANICAL LOCK** (with additional leg on male)

ALL DIMENSION ARE NOMINAL SIZES

FLOATING SLOTTED BASE			200 per box 16,500 per skid	
	GALVANIZED	STAINLESS STEEL		<p>SLOTTED TAB REQUIRED</p>
16 Ga.	BG-500-16	BS-500-16		
18 Ga.	BG-500-18	BS-500-18		
20 Ga.	BG-500-20	BS-500-20		
22 Ga.	BG-500-22	BS-500-22		
24 Ga.	BG-500-24	BS-500-24		

**SS450 & SS450SL : 1" SNAPLOCK CLIPS**

SNAPLOCK			800 per box 26,400 per skid	
	GALVANIZED	STAINLESS STEEL		<p>PART SHOWN WITH EMBOSS</p>
24 Ga.	SG-114-24 embossed	SS-114-24 embossed		
	SG-114-24-NR w/o emboss	SS-114-24-NR w/o emboss		

**SS550 : 1-1/2" SNAPLOCK**

PART #	QTY:		
SSUL - 196 - 20 Stainless Steel	300 per box 9,900 per skid		

ALL DIMENSION ARE NOMINAL SIZES

**SS550: 1-1/2" SNAPLOCK**

SNAPLOCK CLIP			300 per box 9,900 per skid	
	GALVANIZED	STAINLESS STEEL		
20 Ga.	SG-196-20			
22 Ga.	SG-196-22			

SNAPLOCK CLIP			500 per box 16,500 per skid	
	GALVANIZED	STAINLESS STEEL		
24 Ga.	SG2-196-24	SS2-196-24		

**SS675 : 1-3/4" SNAPLOCK**

UL - SNAPLOCK				
PART #	QTY:			
SGUL-178-18 (Galvanized)	250 per box 8250 per skid			
SSUL-178-18 (Stainless Steel)				

SNAPLOCK CLIP			500 per box 16,500 per skid	
	GALVANIZED	STAINLESS STEEL		
18 Ga.	SG-178-18	SS-178-18		



NEWTECH

NEWTECH



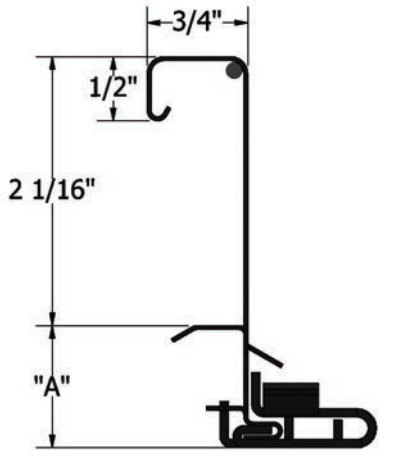
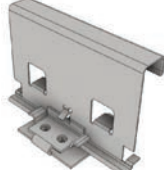

ALL DIMENSION ARE NOMINAL SIZES

### SSQ275

#### UL - FLOATING ARCHITECTURAL CLIPS

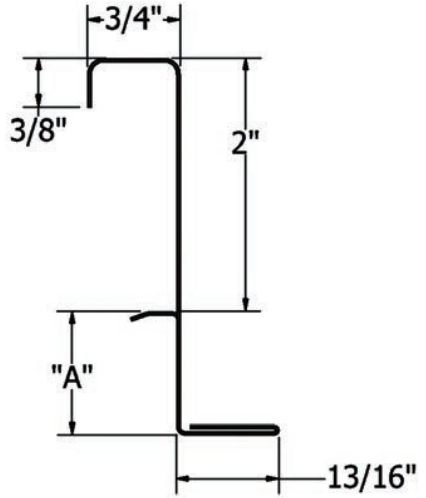
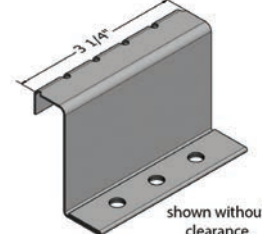
PART #	"A" DIM.		NC-XXXXX-3   STANDARD IN-STOCK BASE
NC-33003-3 (-S)	1/2"		 <p><b>TAB:</b> galvanized 22ga. <b>BASE:</b> galvanized 16ga. <b>PART WIDTH:</b> 4-1/4"</p>
NC-33004-3 (-S)	1"		
NC-33003-6 (-S)	1/2"		 <p><b>TAB:</b> galvanized 22ga. <b>BASE:</b> galvanized 16ga. <b>PART WIDTH:</b> 4-1/4"</p>
* NC-33004-6 (-S)	1"		
<b>QTY:</b>			
110 per box 3630 per skid			
*(NC-33004-6) 100 per box 3300 per skid			

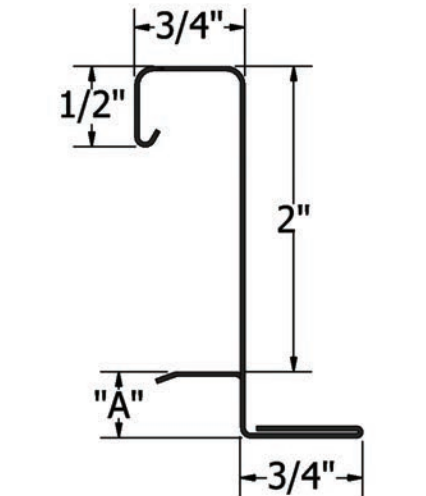
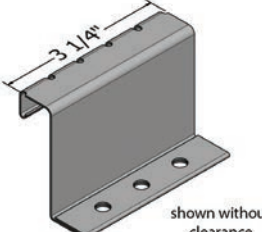
#### UL - FIXED CLIPS



PART #	"A" DIM.		 <p>shown without clearance</p>
NCF-33001 (-S)	3/8" STANDOFF		
<b>QTY:</b>			
225 per box 7425 per skid			
22ga. galvanized			
PART #	"A" DIM.		 <p>shown without clearance</p>
NCF-33015 (-S)	0" CLEARANCE		
NCF-33016 (-S)	1/2" STANDOFF		
NCF-33018 (-S)	1" STANDOFF		
<b>QTY:</b>			
Call (866) 766-3254			
22ga. galvanized			

NEWTECH

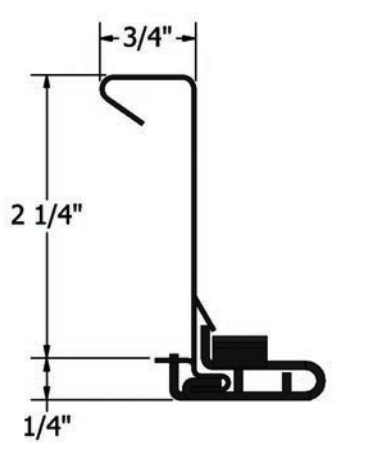
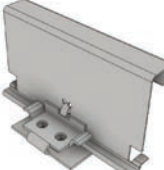

ALL DIMENSION ARE NOMINAL SIZES

### TRQ250 : TRAPEZOIDAL

#### UL - FLOATING ARCHITECTURAL CLIPS

PART #	QTY:		NC-XXXXX-3   STANDARD IN-STOCK BASE
NC-33021-3 (-S)	120 per box 39600 per skid		 <p><b>TAB:</b> galvanized 22ga. <b>BASE:</b> galvanized 16ga. <b>PART WIDTH:</b> 4-1/4"</p>
NC-33021-6 (-S)	110 per box 3630 per skid		
<b>QTY:</b>			

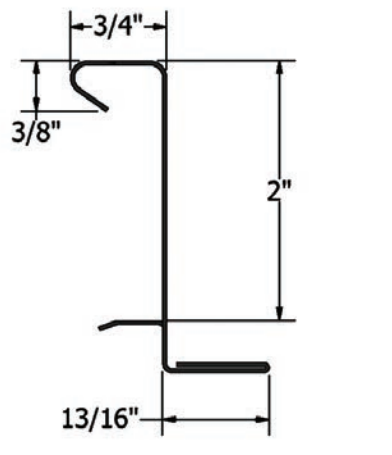
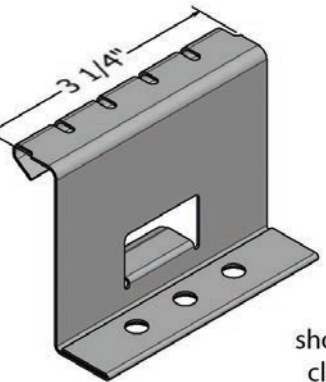
#### UL - FIXED CLIPS

PART #	QTY:		 <p>shown with clearance</p>
NCF-33006 (-S)	225 per box 7425 per skid		
<b>QTY:</b>			

NEWTECH





ALL DIMENSION ARE NOMINAL SIZES

# ZIMMERMAN

## SLC1000 : 1" Snaplock

SNAPLOCK CLIP		500 per box 16,500 per skid	
24 Ga.	GALVANIZED		
	SGZ2-100-24		

## SLC1750 : 1-3/4" Snaplock

UL - SNAPLOCK CLIP		500 per box 16,500 per skid	
<b>PART #</b>	<b>QTY:</b>		
SGUL-178-18 (Galvanized)	250 per box 8250 per skid		
SSUL-178-18 (Stainless Steel)			

SNAPLOCK CLIP		500 per box 16,500 per skid	
18 Ga.	GALVANIZED		
	SG-178-18		
	STAINLESS STEEL		
	SS-178-18		



ALL DIMENSION ARE NOMINAL SIZES

SS1000: 1" MECHANICAL LOCK

## SS1000 : 1" Mechanical Lock

FIXED			1,000 per box 33,000 per skid	
24 Ga.	GALVANIZED	STAINLESS STEEL		
	FG-100-24	FS-100-24		
26 Ga.	FG-100-26	FS-100-26		

FLOATING INTERLOCKING BASE			500 per box 33,000 per skid	
22 Ga.	GALVANIZED	STAINLESS STEEL		
	BG-300-22 w/o emboss	BS-300-22 w/o emboss		
	BGE-300-22 embossed	BSE-300-22 embossed		

FLOATING INTERLOCKING TAB			500 per box 33,000 per skid	
24 Ga.	GALVANIZED	STAINLESS STEEL		
	TG3-100-24	TS3-100-24		
26 Ga.	TG3-100-26	TS3-100-26 NON-STOCK ITEM		

FLOATING SLOTTED BASE			250 per box 16,500 per skid	
16 Ga.	GALVANIZED	STAINLESS STEEL		
	BG-500-16	BS-500-16		
18 Ga.	BG-500-18	BS-500-18		
20 Ga.	BG-500-20	BS-500-20		
22 Ga.	BG-500-22	BS-500-22		
24 Ga.	BG-500-24	BS-500-24		



ALL DIMENSION ARE NOMINAL SIZES

FLOATING SLOTTED TAB			500 per box 33,000 per skid	
	GALVANIZED	STAINLESS STEEL		
24 Ga.	TG-100-24	TS-100-24		
26 Ga.	TG-100-26	TS-100-26		SLOTTED BASE REQUIRED

**SS1500 : 1-1/2" Mechanical Lock Curved**

FIXED			500 per box 16,500 per skid	
	GALVANIZED	STAINLESS STEEL		
24 Ga.	FG-158-24	FS-158-24		
26 Ga.	FG-158-26	FS-158-26		

FIXED			200 per box 6,600 per skid	
	GALVANIZED	STAINLESS STEEL		
24 Ga.	FG6-158-24	FS6-158-24		
26 Ga.	FG6-158-26	FS6-158-26		

FLOATING INTERLOCKING BASE			500 per box 33,000 per skid	
	GALVANIZED	STAINLESS STEEL		
22 Ga.	BG-300-22 w/o emboss	BS-300-22 w/o emboss		INTERLOCKING TAB REQUIRED
	BGE-300-22 embossed	BSE-300-22 embossed		



ALL DIMENSION ARE NOMINAL SIZES

SS1500: 1-1/2" MECHANICAL LOCK

FLOATING INTERLOCKING TAB			500 per box 16,500 per skid	
	GALVANIZED	STAINLESS STEEL		
24 Ga.	TG3-150-24	TS3-150-24		
26 Ga.	TG3-150-26	TS3-150-26 NON-STOCK ITEM		INTERLOCKING BASE REQUIRED

FLOATING SLOTTED BASE			250 per box 16,500 per skid	
	GALVANIZED	STAINLESS STEEL		
16 Ga.	BG-500-16	BS-500-16		
18 Ga.	BG-500-18	BS-500-18		
20 Ga.	BG-500-20	BS-500-20		
22 Ga.	BG-500-22	BS-500-22		
24 Ga.	BG-500-24	BS-500-24		SLOTTED TAB REQUIRED

FLOATING SLOTTED TAB			500 per box 16,500 per skid	
	GALVANIZED	STAINLESS STEEL		
24 Ga.	TG-150-24	TS-150-24		
26 Ga.	TG-150-26	TS-150-26		SLOTTED BASE REQUIRED

**SLC1500 : 1-1/2" Snaplock**

SNAPLOCK CLIP			500 per box 16,500 per skid	
	GALVANIZED			
24 Ga.	SGZ2-100-24			

ZIMMERMAN

ZIMMERMAN



ALL DIMENSION ARE NOMINAL SIZES

**SS2000 : 2" Mechanical Lock**  
(with 90 degree leg)

UL - FLOATING ARCHITECTURAL CLIPS			
PART #	"A" DIM.		
NC-33003-3 (-S)	1/2"		NC-XXXXX-3   <b>STANDARD IN-STOCK BASE</b>
NC-33004-3 (-S)	1"		<b>TAB:</b> galvanized 22ga. <b>BASE:</b> galvanized 16ga. <b>PART WIDTH:</b> 4-1/4"
NC-33003-6 (-S)	1/2"		NC-XXXXX-6   <b>OPTIONAL PURLIN STABILIZER</b>
* NC-33004-6 (-S)	1"		
<b>QTY:</b>			
110 per box 3630 per skid			
*(NC-33004-6)			
100 per box 3300 per skid			
PART #	"A" DIM.		
NC-33009-3 (-S)	1/2"		NC-XXXXX-3   <b>STANDARD IN-STOCK BASE</b>
NC-33010-3 (-S)	1"		<b>TAB:</b> galvanized 22ga. <b>BASE:</b> galvanized 16ga. <b>PART WIDTH:</b> 4-1/4"
NC-33009-6 (-S)	1/2"		NC-XXXXX-6   <b>OPTIONAL PURLIN STABILIZER</b>
NC-33010-6 (-S)	1"		
<b>QTY:</b>			
110 per box 3630 per skid			

UL - FIXED CLIPS				
PART #	"A" DIM.			
NCF-33000 (-S)	0" CLEARANCE		shown without clearance	
NCF-33001 (-S)	3/8" STANDOFF			shown with clearance
NCF-33002 (-S)	1-3/8" STANDOFF			
<b>QTY:</b>				
225 per box 7425 per skid				
22ga. galvanized				



ALL DIMENSION ARE NOMINAL SIZES

**SS2000: 2" MECHANICAL LOCK** (with 90 degree leg)

			FIXED	300 per box 9,900 per skid
	GALVANIZED	STAINLESS STEEL		
22 Ga.	FG-218-22	FS-218-22		
24 Ga.	FG-218-24	FS-218-24		

			FLOATING INTERLOCKING BASE	500 per box 33,000 per skid
	GALVANIZED	STAINLESS STEEL		
22 Ga.	BG-300-22 w/o emboss	BS-300-22 w/o emboss		INTERLOCKING TAB REQUIRED
	BGE-300-22 embossed	BSE-300-22 embossed		

			FLOATING INTERLOCKING TAB	400 per box 13,200 per skid
	GALVANIZED	STAINLESS STEEL		
24 Ga.	TG3-200-24	TS3-200-24		INTERLOCKING BASE REQUIRED
26 Ga.	TG3-200-26	TS3-200-26 NON-STOCK ITEM		

			FLOATING SLOTTED BASE	250 per box 16,500 per skid
	GALVANIZED	STAINLESS STEEL		
16 Ga.	BG-500-16	BS-500-16		SLOTTED TAB REQUIRED
18 Ga.	BG-500-18	BS-500-18		
20 Ga.	BG-500-20	BS-500-20		
22 Ga.	BG-500-22	BS-500-22		
24 Ga.	BG-500-24	BS-500-24		

ZIMMERMAN

ZIMMERMAN



**SS2000:** 2" MECHANICAL LOCK (with 90 degree leg)

ALL DIMENSION ARE NOMINAL SIZES

FLOATING SLOTTED TAB			500 per box 16,500 per skid	
	GALVANIZED	STAINLESS STEEL		
22 Ga.	TG-200-22	TS-200-22		
24 Ga.	TG-200-24	TS-200-24		

**SS2000A:** 2" Mechanical Lock (with 45 degree leg)

UL - FLOATING ARCHITECTURAL CLIPS			
PART #	"A" DIM.	NC-XXXX-3   STANDARD IN-STOCK BASE	
* NC-33001-3 (-S)	1/2"		<p><b>TAB:</b> galvanized 22ga. <b>BASE:</b> galvanized 16ga. <b>PART WIDTH:</b> 4-1/4"</p>
NC-33002-3 (-S)	1"		
NC-33001-6 (-S)	1/2"		
NC-33002-6 (-S)	1"		
<b>QTY:</b>			NC-XXXX-6   OPTIONAL PURLIN STABILIZER <p><b>TAB:</b> galvanized 22ga. <b>BASE:</b> galvanized 16ga. <b>PART WIDTH:</b> 4-1/4"</p>
*(NC-33001-3)			
120 per box 3960 per skid			
110 per box 3630 per skid			

UL - FLOATING ARCHITECTURAL CLIPS			
PART #	"A" DIM.	NC-XXXX-3   STANDARD IN-STOCK BASE	
NC-33009-3 (-S)	1/2"		<p><b>TAB:</b> galvanized 22ga. <b>BASE:</b> galvanized 16ga. <b>PART WIDTH:</b> 4-1/4"</p>
NC-33010-3 (-S)	1"		
NC-33009-6 (-S)	1/2"		
NC-33010-6 (-S)	1"		
<b>QTY:</b>			NC-XXXX-6   OPTIONAL PURLIN STABILIZER <p><b>TAB:</b> galvanized 22ga. <b>BASE:</b> galvanized 16ga. <b>PART WIDTH:</b> 4-1/4"</p>
110 per box 3630 per skid			



ALL DIMENSION ARE NOMINAL SIZES

**SS2000A:** 2" MECHANICAL LOCK ( with 45 degree leg)

UL - FIXED CLIPS			
PART #	"A" DIM.		
NCF-33005 (-S)	0" CLEARANCE		
NCF-33006 (-S)	1/2" STANDOFF		
NCF-33007 (-S)	1" STANDOFF		
<b>QTY:</b>			
225 per box 7425 per skid			
22ga. galvanized			

FIXED				300 per box 9,900 per skid	
	GALVANIZED	STAINLESS STEEL			
22 Ga.	FG-218-22	FS-218-22			
24 Ga.	FG-218-24	FS-218-24			

FLOATING INTERLOCKING BASE				500 per box 33,000 per skid	
	GALVANIZED	STAINLESS STEEL			
22 Ga.	BG-300-22 w/o emboss	BS-300-22 w/o emboss			
	BGE-300-22 embossed	BSE-300-22 embossed			

ZIMMERMAN

ZIMMERMAN



**SS2000A: 2" MECHANICAL LOCK (with 45 degree leg)**

ALL DIMENSION ARE NOMINAL SIZES

FLOATING INTERLOCKING TAB			400 per box 13,200 per skid	
	GALVANIZED	STAINLESS STEEL		<p>INTERLOCKING BASE REQUIRED</p>
24 Ga.	TG3-200-24	TS3-200-24		
26 Ga.	TG3-200-26	TS3-200-26 NON-STOCK ITEM		

FLOATING SLOTTED TAB			500 per box 16,500 per skid	
	GALVANIZED	STAINLESS STEEL		<p>SLOTTED BASE REQUIRED</p>
22 Ga.	TG-200-22	TS-200-22		
24 Ga.	TG-200-24	TS-200-24		

FLOATING SLOTTED BASE			250 per box 16,500 per skid	
	GALVANIZED	STAINLESS STEEL		<p>SLOTTED TAB REQUIRED</p>
16 Ga.	BG-500-16	BS-500-16		
18 Ga.	BG-500-18	BS-500-18		
20 Ga.	BG-500-20	BS-500-20		
22 Ga.	BG-500-22	BS-500-22		
24 Ga.	BG-500-24	BS-500-24		



ALL DIMENSION ARE NOMINAL SIZES

**SS2500: 2-1/2" Mechanical Lock**

FIXED CLIPS			300 per box 9900 per skid	
	GALVANIZED	STAINLESS STEEL		
22 Ga.	FG-258-22	FS-258-22		
24 Ga.	FG-258-24	FS-258-24		

FLOATING INTERLOCKING BASE			500 per box 33,000 per skid	
	GALVANIZED	STAINLESS STEEL		<p>INTERLOCKING TAB REQUIRED</p>
22 Ga.	BG-300-22 w/o emboss	BS-300-22 w/o emboss		
	BGE-300-22 embossed	BSE-300-22 embossed		

FLOATING INTERLOCKING TAB			400 per box 13,200 per skid	
	GALVANIZED	STAINLESS STEEL		<p>INTERLOCKING BASE REQUIRED</p>
24 Ga.	TG3-250-24	TS3-250-24		
26 Ga.	TG3-250-26	TS3-250-26 NON-STOCK ITEM		

FLOATING SLOTTED TAB			500 per box 16,500 per skid	
	GALVANIZED	STAINLESS STEEL		<p>SLOTTED BASE REQUIRED</p>
22 Ga.	TG-250-22	TS-250-22		
24 Ga.	TG-250-24	TS-250-24		

ZIMMERMAN

ZIMMERMAN



**SS2500: 2-1/2" MECHANICAL LOCK**

ALL DIMENSION ARE NOMINAL SIZES

FLOATING SLOTTED BASE			250 per box 16,500 per skid	
	GALVANIZED	STAINLESS STEEL		
16 Ga.	BG-500-16	BS-500-16		
18 Ga.	BG-500-18	BS-500-18		
20 Ga.	BG-500-20	BS-500-20		
22 Ga.	BG-500-22	BS-500-22		
24 Ga.	BG-500-24	BS-500-24		

**TSS-3000A & TSS-3000B**

UL - FLOATING TRAPEZOIDAL CLIPS		NC-XXXXX-3   STANDARD IN-STOCK BASE	
<b>PART #</b>	<b>QTY:</b>		
NC-34526-3-S	130 per box 4290 per skid		
NC-34526-6-S	100 per box 3300 per skid		
		NC-XXXXX-6   OPTIONAL PURLIN STABILIZER	
			<b>TAB:</b> galvanized 22ga. <b>BASE:</b> galvanized 16ga. <b>PART WIDTH:</b> 4-1/4"
			<b>TAB:</b> galvanized 22ga. <b>BASE:</b> galvanized 16ga. <b>PART WIDTH:</b> 4-1/4"

FLOATING TRAPEZOIDAL CLIPS			
<b>PART NUMBER</b>	<b>"A"</b>		
NC-34502-3 (-S)	3-1/4"		
NC-34502-6 (-S)	3-1/4"		
<b>Tab:</b> 22ga. G90 Galvanized <b>Base:</b> 16 ga. Galvanized Factory Applied Sealant Optional			

ALL DIMENSION ARE NOMINAL SIZES

**ENGLERT**

**A1000 : 1-1/2" SNAPLOCK**

SNAPLOCK			800 per box 26,400 per skid	
	GALVANIZED	STAINLESS STEEL		
24 Ga.	SG-114-24 embossed	SS-114-24 embossed		
	SG-114-24-NR w/o emboss	SS-114-24-NR w/o emboss		

**A1300 : 1-1/2" MECHANICAL LOCK**

FIXED			500 per box 16,500 per skid	
	GALVANIZED	STAINLESS STEEL		
24 Ga.	FG-158-24	FS-158-24		
26 Ga.	FG-158-26	FS-158-26		

FIXED			200 per box 6,600 per skid	
	GALVANIZED	STAINLESS STEEL		
24 Ga.	FG6-158-24	FS6-158-24		
26 Ga.	FG6-158-26	FS6-158-26		

**A1300: 1-1/2" MECHANICAL LOCK**

ALL DIMENSION ARE NOMINAL SIZES

FLOATING INTERLOCKING BASE			500 per box 33,000 per skid	
	GALVANIZED	STAINLESS STEEL		
22 Ga.	BG-300-22 w/o emboss	BS-300-22 w/o emboss		INTERLOCKING TAB REQUIRED
	BGE-300-22 embossed	BSE-300-22 embossed		

FLOATING INTERLOCKING TAB			500 per box 16,500 per skid	
	GALVANIZED	STAINLESS STEEL		
24 Ga.	TG3-150-24	TS3-150-24		INTERLOCKING BASE REQUIRED
26 Ga.	TG3-150-26	TS3-150-26 NON-STOCK ITEM		

FLOATING SLOTTED BASE			250 per box 16,500 per skid	
	GALVANIZED	STAINLESS STEEL		
16 Ga.	BG-500-16	BS-500-16		SLOTTED TAB REQUIRED
18 Ga.	BG-500-18	BS-500-18		
20 Ga.	BG-500-20	BS-500-20		
22 Ga.	BG-500-22	BS-500-22		
24 Ga.	BG-500-24	BS-500-24		

FLOATING SLOTTED TAB			500 per box 16,500 per skid	
	GALVANIZED	STAINLESS STEEL		
24 Ga.	TG-150-24	TS-150-24		SLOTTED BASE REQUIRED
26 Ga.	TG-150-26	TS-150-26		

ALL DIMENSION ARE NOMINAL SIZES

**A1301 : 1" MECHANICAL LOCK**

FIXED			1,000 per box 33,000 per skid	
	GALVANIZED	STAINLESS STEEL		
24 Ga.	FG-100-24	FS-100-24		
26 Ga.	FG-100-26	FS-100-26		

FLOATING INTERLOCKING BASE			500 per box 33,000 per skid	
	GALVANIZED	STAINLESS STEEL		
22 Ga.	BG-300-22 w/o emboss	BS-300-22 w/o emboss		INTERLOCKING TAB REQUIRED
22 Ga.	BGE-300-22 embossed	BSE-300-22 embossed		

FLOATING INTERLOCKING TAB			500 per box 33,000 per skid	
	GALVANIZED	STAINLESS STEEL		
24 Ga.	TG3-100-24	TS3-100-24		INTERLOCKING BASE REQUIRED
26 Ga.	TG3-100-26	TS3-100-26 NON-STOCK ITEM		

FLOATING SLOTTED TAB			500 per box 33,000 per skid	
	GALVANIZED	STAINLESS STEEL		
24 Ga.	TG-100-24	TS-100-24		SLOTTED BASE REQUIRED
26 Ga.	TG-100-26	TS-100-26		

ENGLERT

ENGLERT

**A130: 1" MECHANICAL LOCK**

ALL DIMENSION ARE NOMINAL SIZES

FLOATING SLOTTED BASE			250 per box 16,500 per skid	
	GALVANIZED	STAINLESS STEEL		
16 Ga.	<b>BG-500-16</b>	<b>BS-500-16</b>		
18 Ga.	<b>BG-500-18</b>	<b>BS-500-18</b>		
20 Ga.	<b>BG-500-20</b>	<b>BS-500-20</b>		
22 Ga.	<b>BG-500-22</b>	<b>BS-500-22</b>		
24 Ga.	<b>BG-500-24</b>	<b>BS-500-24</b>		

ALL DIMENSION ARE NOMINAL SIZES

**C1300: 1-1/2" MECHANICAL LOCK**

FLOATING INTERLOCKING BASE			500 per box 33,000 per skid	
	GALVANIZED	STAINLESS STEEL		
22 Ga.	<b>BG-300-22</b> w/o emboss	<b>BS-300-22</b> w/o emboss		
22 Ga.	<b>BGE-300-22</b> embossed	<b>BSE-300-22</b> embossed		

FLOATING INTERLOCKING TAB			500 per box 16,500 per skid	
	GALVANIZED	STAINLESS STEEL		
24 Ga.	<b>TG3-150-24</b>	<b>TS3-150-24</b>		
26 Ga.	<b>TG3-150-26</b>	<b>TS3-150-26</b> NON-STOCK ITEM		

**C1300 : 1-1/2" MECHANICAL LOCK**

FIXED				
	GALVANIZED	STAINLESS STEEL		
24 Ga.	<b>FG-158-24</b>	<b>FS-158-24</b>		
26 Ga.	<b>FG-158-26</b>	<b>FS-158-26</b>		

24 Ga.	<b>FG6-158-24</b>	<b>FS6-158-24</b>		
26 Ga.	<b>FG6-158-26</b>	<b>FS6-158-26</b>		

FLOATING SLOTTED BASE			250 per box 16,500 per skid	
	GALVANIZED	STAINLESS STEEL		
16 Ga.	<b>BG-500-16</b>	<b>BS-500-16</b>		
18 Ga.	<b>BG-500-18</b>	<b>BS-500-18</b>		
20 Ga.	<b>BG-500-20</b>	<b>BS-500-20</b>		
22 Ga.	<b>BG-500-22</b>	<b>BS-500-22</b>		
24 Ga.	<b>BG-500-24</b>	<b>BS-500-24</b>		

FLOATING SLOTTED TAB			500 per box 16,500 per skid	
	GALVANIZED	STAINLESS STEEL		
24 Ga.	<b>TG-150-24</b>	<b>TS-150-24</b>		
26 Ga.	<b>TG-150-26</b>	<b>TS-150-26</b>		

ENGLERT

ENGLERT



ALL DIMENSION ARE NOMINAL SIZES

### C1301 : 1" MECHANICAL LOCK

FIXED			1,000 per box 33,000 per skid	
	GALVANIZED	STAINLESS STEEL		
24 Ga.	<b>FG-100-24</b>	<b>FS-100-24</b>		
26 Ga.	<b>FG-100-26</b>	<b>FS-100-26</b>		

FLOATING INTERLOCKING BASE			500 per box 33,000 per skid	
	GALVANIZED	STAINLESS STEEL		
22 Ga.	<b>BG-300-22</b> w/o emboss	<b>BS-300-22</b> w/o emboss		
22 Ga.	<b>BGE-300-22</b> embossed	<b>BSE-300-22</b> embossed		

FLOATING INTERLOCKING TAB			500 per box 33,000 per skid	
	GALVANIZED	STAINLESS STEEL		
24 Ga.	<b>TG3-100-24</b>	<b>TS3-100-24</b>		
26 Ga.	<b>TG3-100-26</b>	<b>TS3-100-26</b> NON-STOCK ITEM		

FLOATING SLOTTED TAB			500 per box 33,000 per skid	
	GALVANIZED	STAINLESS STEEL		
24 Ga.	<b>TG-100-24</b>	<b>TS-100-24</b>		
26 Ga.	<b>TG-100-26</b>	<b>TS-100-26</b>		

ALL DIMENSION ARE NOMINAL SIZES

C1301: 1" MECHANICAL LOCK

FLOATING SLOTTED BASE			250 per box 16,500 per skid	
	GALVANIZED	STAINLESS STEEL		
16 Ga.	<b>BG-500-16</b>	<b>BS-500-16</b>		
18 Ga.	<b>BG-500-18</b>	<b>BS-500-18</b>		
20 Ga.	<b>BG-500-20</b>	<b>BS-500-20</b>		
22 Ga.	<b>BG-500-22</b>	<b>BS-500-22</b>		
24 Ga.	<b>BG-500-24</b>	<b>BS-500-24</b>		

### C2400 : 2" MECHANICAL LOCK

UL - FLOATING ARCHITECTURAL CLIPS			NC-XXXXX-3   STANDARD IN-STOCK BASE	
PART #	"A" DIM.			
* NC-33001-3 (-S)	1/2"			<b>TAB:</b> galvanized 22ga. <b>BASE:</b> galvanized 16ga. <b>PART WIDTH:</b> 4-1/4"
NC-33002-3 (-S)	1"			
NC-33001-6 (-S)	1/2"			<b>TAB:</b> galvanized 22ga. <b>BASE:</b> galvanized 16ga. <b>PART WIDTH:</b> 4-1/4"
NC-33002-6 (-S)	1"			
<b>QTY:</b> *(NC-33001-3) 120 per box 3960 per skid  110 per box 3630 per skid				

ENGLERT

ENGLERT

C2400: 2" MECHANICAL LOCK

ALL DIMENSION ARE NOMINAL SIZES

**UL - FLOATING ARCHITECTURAL CLIPS**

PART #	"A" DIM.		NC-XXXXX-3   <b>STANDARD IN-STOCK BASE</b>		
NC-33009-3 (-S)	1/2"				<b>TAB:</b> galvanized 22ga. <b>BASE:</b> galvanized 16ga. <b>PART WIDTH:</b> 4-1/4"
NC-33010-3 (-S)	1"				
NC-33009-6 (-S)	1/2"				
NC-33010-6 (-S)	1"				
<b>QTY:</b>			NC-XXXXX-6   <b>OPTIONAL PURLIN STABILIZER</b>		
110 per box 3630 per skid				<b>TAB:</b> galvanized 22ga. <b>BASE:</b> galvanized 16ga. <b>PART WIDTH:</b> 4-1/4"	

**UL - FIXED CLIPS**

PART #	"A" DIM.				
NCF-33005 (-S)	0" CLEARANCE				shown without clearance
NCF-33006 (-S)	1/2" STANDOFF				
NCF-33007 (-S)	1" STANDOFF				
<b>QTY:</b>					shown with clearance
225 per box 7425 per skid					
22ga. galvanized					

**FIXED** 300 per box  
9,900 per skid

	GALVANIZED	STAINLESS STEEL				
22 Ga.	FG-218-22	FS-218-22				
24 Ga.	FG-218-24	FS-218-24				

ALL DIMENSION ARE NOMINAL SIZES

C2400: 2" MECHANICAL LOCK

**FLOATING INTERLOCKING BASE** 500 per box  
33,000 per skid

	GALVANIZED	STAINLESS STEEL				
22 Ga.	BG-300-22 w/o emboss	BS-300-22 w/o emboss				
24 Ga.	BGE-300-22 embossed	BSE-300-22 embossed				

**FLOATING INTERLOCKING TAB** 400 per box  
13,200 per skid

	GALVANIZED	STAINLESS STEEL				
24 Ga.	TG3-200-24	TS3-200-24				
26 Ga.	TG3-200-26	TS3-200-26				

**FLOATING SLOTTED BASE** 250 per box  
16,500 per skid

	GALVANIZED	STAINLESS STEEL				
16 Ga.	BG-500-16	BS-500-16				
18 Ga.	BG-500-18	BS-500-18				
20 Ga.	BG-500-20	BS-500-20				
22 Ga.	BG-500-22	BS-500-22				
24 Ga.	BG-500-24	BS-500-24				



**FLOATING SLOTTED TAB** 500 per box  
16,500 per skid

	GALVANIZED	STAINLESS STEEL				
22 Ga.	TG-200-22	TS-200-22				
24 Ga.	TG-200-24	TS-200-24				

ALL DIMENSION ARE NOMINAL SIZES

**S2000 : 1-3/4" SNAPLOCK**

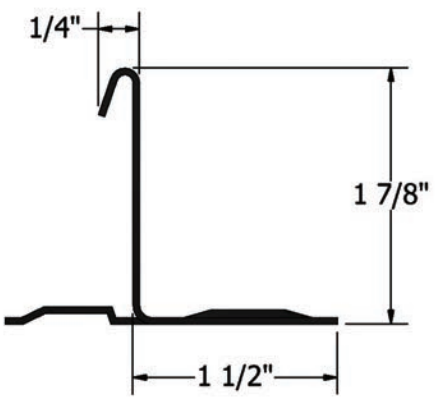
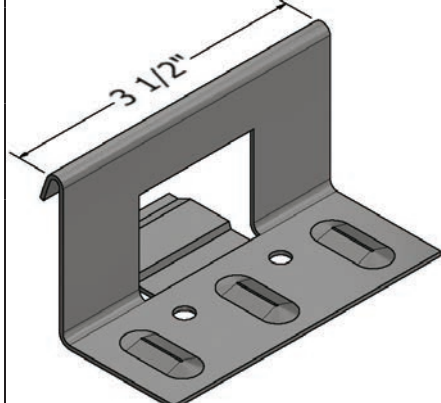
UL - SNAPLOCK CLIP

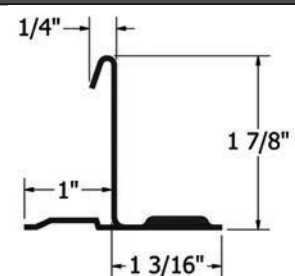
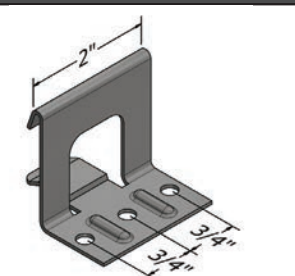

PART #	QTY:		
<b>SGUL-178-18</b> (Galvanized)  <b>SSUL-178-18</b> (Stainless Steel)	250 per box 8250 per skid		
			

UL - SNAPLOCK CLIP 500 per box  
16,500 per skid

	GALVANIZED	STAINLESS STEEL		
18 Ga.	<b>SG-178-18</b>	<b>SS-178-18</b>		

**S2400 : 2" MECHANICAL LOCK**

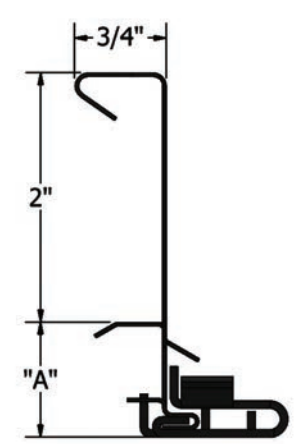

UL - FLOATING ARCHITECTURAL CLIPS

PART #	"A" DIM.		NC-XXXXX-3   STANDARD IN-STOCK BASE
* NC-33001-3 (-S)	1/2"		
NC-33002-3 (-S)	1"	NC-XXXXX-6   OPTIONAL PURLIN STABILIZER  <p>TAB: galvanized 22ga. BASE: galvanized 16ga. PART WIDTH: 4-1/4"</p>	
NC-33001-6 (-S)	1/2"		
NC-33002-6 (-S)	1"		
<b>QTY:</b> *(NC-33001-3) 120 per box 3960 per skid  110 per box 3630 per skid			

ALL DIMENSION ARE NOMINAL SIZES

**S2400: 2" MECHANICAL LOCK**

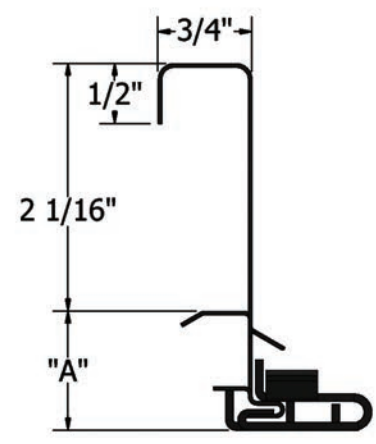
UL - FLOATING ARCHITECTURAL CLIPS

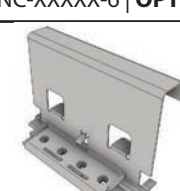
PART #	"A" DIM.		NC-XXXXX-3   STANDARD IN-STOCK BASE
NC-33009-3 (-S)	1/2"		
NC-33010-3 (-S)	1"	NC-XXXXX-6   OPTIONAL PURLIN STABILIZER  <p>TAB: galvanized 22ga. BASE: galvanized 16ga. PART WIDTH: 4-1/4"</p>	
NC-33009-6 (-S)	1/2"		
NC-33010-6 (-S)	1"		
<b>QTY:</b> 110 per box 3630 per skid			

UL - FIXED CLIPS

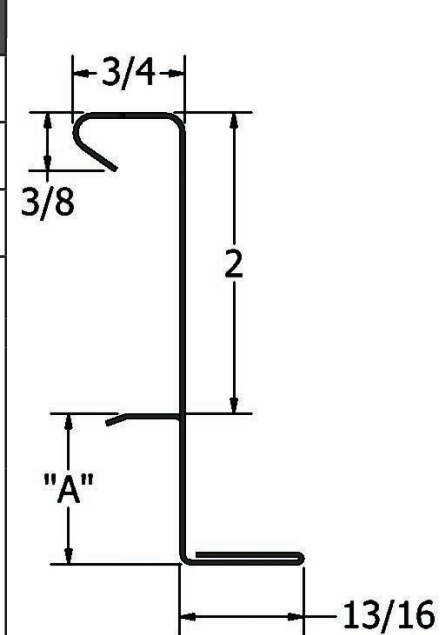
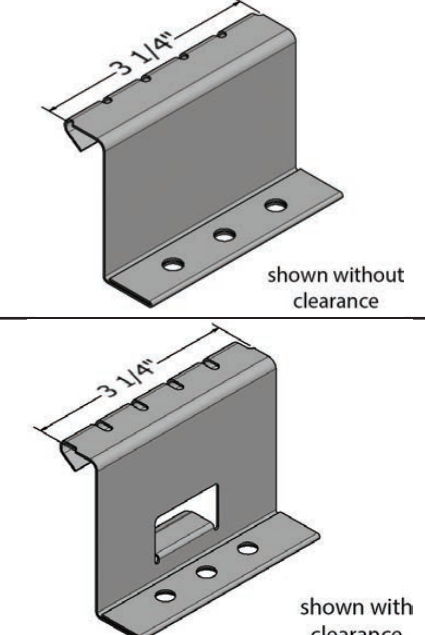
PART #	"A" DIM.		
NCF-33005 (-S)	0" CLEARANCE		
NCF-33006 (-S)	1/2" STANDOFF	shown with clearance	
NCF-33007 (-S)	1" STANDOFF		
<b>QTY:</b> 225 per box 7425 per skid  22ga. galvanized			

FIXED 300 per box  
9,900 per skid

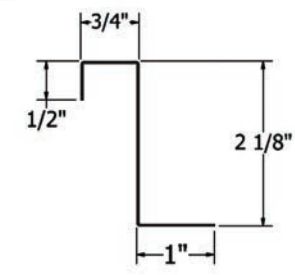
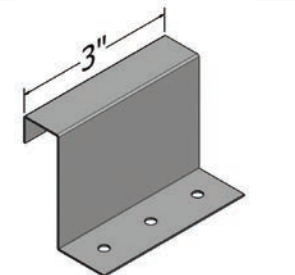
	GALVANIZED	STAINLESS STEEL		
22 Ga.	<b>FG-218-22</b>	<b>FS-218-22</b>		
24 Ga.	<b>FG-218-24</b>	<b>FS-218-24</b>		

ENGLERT

ENGLERT

**S2400: 2" MECHANICAL LOCK**

ALL DIMENSION ARE NOMINAL SIZES

FLOATING INTERLOCKING BASE			500 per box 33,000 per skid	
	GALVANIZED	STAINLESS STEEL		
22 Ga.	BG-300-22 w/o emboss	BS-300-22 w/o emboss		INTERLOCKING TAB REQUIRED
22 Ga.	BGE-300-22 embossed	BSE-300-22 embossed		

FLOATING INTERLOCKING TAB			400 per box 13,200 per skid	
	GALVANIZED	STAINLESS STEEL		
24 Ga.	TG3-200-24	TS3-200-24		INTERLOCKING BASE REQUIRED
26 Ga.	TG3-200-26	TS3-200-26		

FLOATING SLOTTED BASE			250 per box 16,500 per skid	
	GALVANIZED	STAINLESS STEEL		
16 Ga.	BG-500-16	BS-500-16		SLOTTED TAB REQUIRED
18 Ga.	BG-500-18	BS-500-18		
20 Ga.	BG-500-20	BS-500-20		
22 Ga.	BG-500-22	BS-500-22		
24 Ga.	BG-500-24	BS-500-24		

FLOATING SLOTTED TAB			500 per box 16,500 per skid	
	GALVANIZED	STAINLESS STEEL		
22 Ga.	TG-200-22	TS-200-22		SLOTTED BASE REQUIRED
24 Ga.	TG-200-24	TS-200-24		

ALL DIMENSION ARE NOMINAL SIZES

**S2500 : 2" MECHANICAL LOCK**  
(with additional leg on male)

UL - FLOATING ARCHITECTURAL CLIPS			
<b>PART #</b>	<b>"A" DIM.</b>		NC-XXXXX-3   <b>STANDARD IN-STOCK BASE</b>
NC-33003-3 (-S)	1/2"		
NC-33004-3 (-S)	1"		<b>TAB:</b> galvanized 22ga. <b>BASE:</b> galvanized 16ga. <b>PART WIDTH:</b> 4-1/4"
NC-33003-6 (-S)	1/2"		
* NC-33004-6 (-S)	1"		NC-XXXXX-6   <b>OPTIONAL PURLIN STABILIZER</b>
<b>QTY:</b>			
110 per box 3630 per skid			<b>TAB:</b> galvanized 22ga. <b>BASE:</b> galvanized 16ga. <b>PART WIDTH:</b> 4-1/4"
*(NC-33004-6)			
100 per box 3300 per skid			
<b>PART #</b>	<b>"A" DIM.</b>		NC-XXXXX-3   <b>STANDARD IN-STOCK BASE</b>
NC-33009-3 (-S)	1/2"		
NC-33010-3 (-S)	1"		<b>TAB:</b> galvanized 22ga. <b>BASE:</b> galvanized 16ga. <b>PART WIDTH:</b> 4-1/4"
NC-33009-6 (-S)	1/2"		
NC-33010-6 (-S)	1"		NC-XXXXX-6   <b>OPTIONAL PURLIN STABILIZER</b>
<b>QTY:</b>			
110 per box 3630 per skid			<b>TAB:</b> galvanized 22ga. <b>BASE:</b> galvanized 16ga. <b>PART WIDTH:</b> 4-1/4"

UL - FIXED CLIPS			
<b>PART #</b>	<b>"A" DIM.</b>		
NCF-33000 (-S)	0" CLEARANCE		
NCF-33001 (-S)	3/8" STANDOFF		
NCF-33002 (-S)	1-3/8" STANDOFF		
<b>QTY:</b>			
225 per box 7425 per skid			
22ga. galvanized			

ENGLERT

ENGLERT

**S2500: 2" MECHANICAL LOCK**

ALL DIMENSION ARE NOMINAL SIZES

			FIXED		300 per box 9,900 per skid
	GALVANIZED	STAINLESS STEEL			
22 Ga.	<b>FG-218-22</b>	<b>FS-218-22</b>			
24 Ga.	<b>FG-218-24</b>	<b>FS-218-24</b>			

			FLOATING SLOTTED TAB		500 per box 16,500 per skid
	GALVANIZED	STAINLESS STEEL			
22 Ga.	<b>TG-200-22</b>	<b>TS-200-22</b>			
24 Ga.	<b>TG-200-24</b>	<b>TS-200-24</b>			

			FLOATING SLOTTED BASE		250 per box 16,500 per skid
	GALVANIZED	STAINLESS STEEL			
16 Ga.	<b>BG-500-16</b>	<b>BS-500-16</b>			
18 Ga.	<b>BG-500-18</b>	<b>BS-500-18</b>			
20 Ga.	<b>BG-500-20</b>	<b>BS-500-20</b>			
22 Ga.	<b>BG-500-22</b>	<b>BS-500-22</b>			
24 Ga.	<b>BG-500-24</b>	<b>BS-500-24</b>			

			FLOATING INTERLOCKING TAB		400 per box 13,200 per skid
	GALVANIZED	STAINLESS STEEL			
24 Ga.	<b>TG3-200-24</b>	<b>TS3-200-24</b>			
26 Ga.	<b>TG3-200-26</b>	<b>TS3-200-26</b>			

ALL DIMENSION ARE NOMINAL SIZES

**S2500: 2" MECHANICAL LOCK**

			FLOATING INTERLOCKING BASE		500 per box 33,000 per skid
	GALVANIZED	STAINLESS STEEL			
22 Ga.	<b>BG-300-22</b> w/o emboss	<b>BS-300-22</b> w/o emboss			
22 Ga.	<b>BGE-300-22</b> embossed	<b>BSE-300-22</b> embossed			

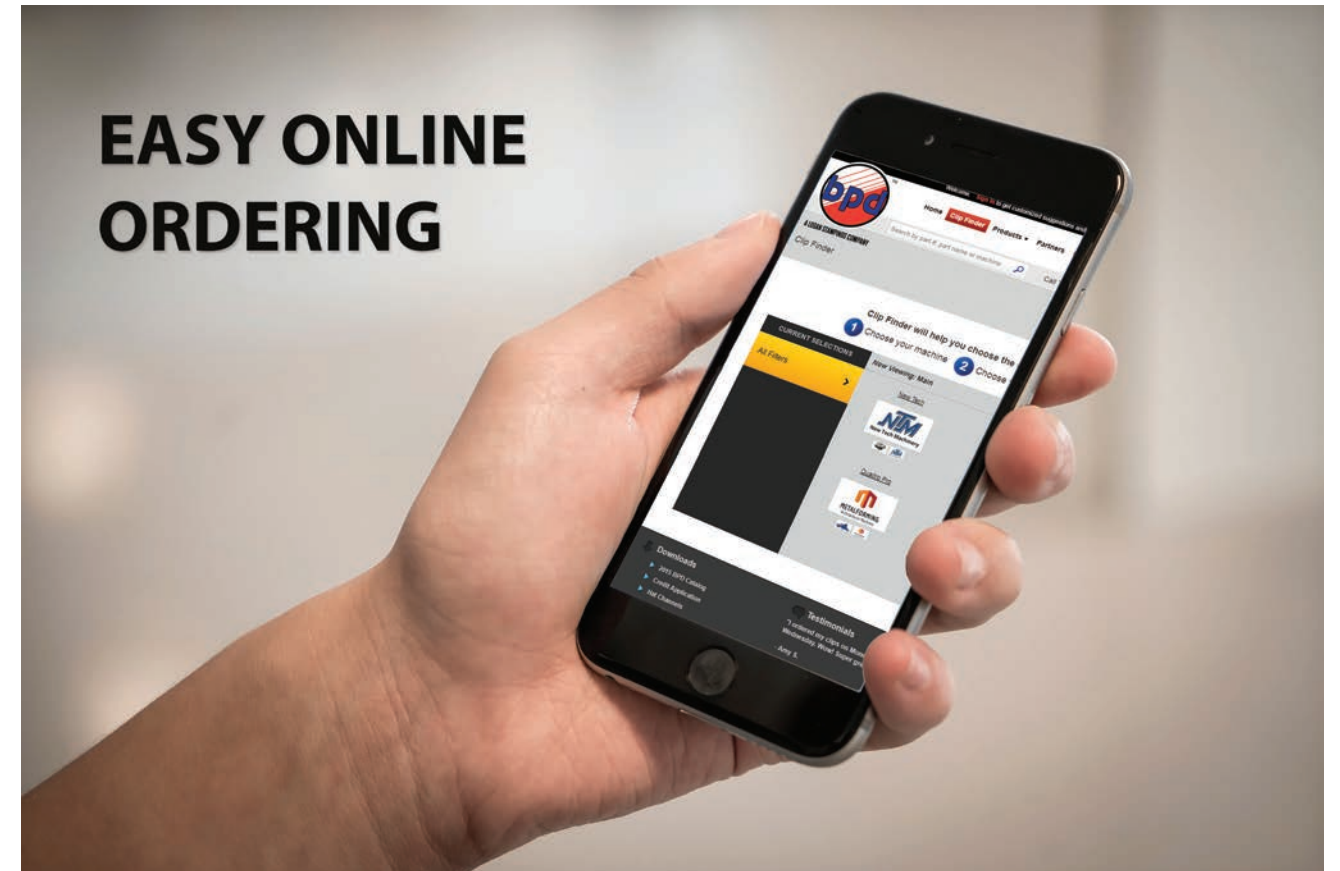

**EASY ONLINE ORDERING**



ALL DIMENSION ARE NOMINAL SIZES

# KNUDSON

## VP-21M - VARIPAN: 1" MECHANICAL LOCK

FIXED			1,000 per box 33,000 per skid	
	GALVANIZED	STAINLESS STEEL		
24 Ga.	FG-100-24	FS-100-24		
26 Ga.	FG-100-26	FS-100-26		

FLOATING INTERLOCKING BASE			500 per box 33,000 per skid	
	GALVANIZED	STAINLESS STEEL		
22 Ga.	BG-300-22 w/o emboss	BS-300-22 w/o emboss		
22 Ga.	BGE-300-22 embossed	BSE-300-22 embossed		

FLOATING INTERLOCKING TAB			500 per box 33,000 per skid	
	GALVANIZED	STAINLESS STEEL		
24 Ga.	TG3-100-24	TS3-100-24		
26 Ga.	TG3-100-26	TS3-100-26 NON-STOCK ITEM		

FLOATING SLOTTED TAB			500 per box 33,000 per skid	
	GALVANIZED	STAINLESS STEEL		
24 Ga.	TG-100-24	TS-100-24		
26 Ga.	TG-100-26	TS-100-26		



ALL DIMENSION ARE NOMINAL SIZES

## VP-21M - VARIPAN: 1" MECHANICAL LOCK

FLOATING SLOTTED BASE			250 per box 16,500 per skid	
	GALVANIZED	STAINLESS STEEL		
16 Ga.	BG-500-16	BS-500-16		
18 Ga.	BG-500-18	BS-500-18		
20 Ga.	BG-500-20	BS-500-20		
22 Ga.	BG-500-22	BS-500-22		
24 Ga.	BG-500-24	BS-500-24		

## VP-21M - VARIPAN: 1-1/2" MECHANICAL LOCK

FIXED			500 per box 16,500 per skid	
	GALVANIZED	STAINLESS STEEL		
24 Ga.	FG-158-24	FS-158-24		
26 Ga.	FG-158-26	FS-158-26		

FIXED			200 per box 6,600 per skid	
	GALVANIZED	STAINLESS STEEL		
24 Ga.	FG6-158-24	FS6-158-24		
26 Ga.	FG6-158-26	FS6-158-26		

KNUDSON

KNUDSON



ALL DIMENSION ARE NOMINAL SIZES

1-1/2" MECHANICAL LOCK

FLOATING INTERLOCKING TAB			500 per box 16,500 per skid	
	GALVANIZED	STAINLESS STEEL		
24 Ga.	TG3-150-24	TS3-150-24		<p>INTERLOCKING BASE REQUIRED</p>
26 Ga.	TG3-150-26	TG3-150-26 NON-STOCK ITEM		

FLOATING INTERLOCKING BASE			500 per box 33,000 per skid	
	GALVANIZED	STAINLESS STEEL		
22 Ga.	BG-300-22 w/o emboss	BS-300-22 w/o emboss		<p>INTERLOCKING TAB REQUIRED</p>
22 Ga.	BGE-300-22 embossed	BSE-300-22 embossed		

FLOATING SLOTTED TAB			500 per box 16,500 per skid	
	GALVANIZED	STAINLESS STEEL		
24 Ga.	TG-150-24	TS-150-24		<p>SLOTTED BASE REQUIRED</p>
26 Ga.	TG-150-26	TS-150-26		

FLOATING SLOTTED BASE			250 per box 16,500 per skid	
	GALVANIZED	STAINLESS STEEL		
16 Ga.	BG-500-16	BS-500-16		<p>SLOTTED TAB REQUIRED</p>
18 Ga.	BG-500-18	BS-500-18		
20 Ga.	BG-500-20	BS-500-20		
22 Ga.	BG-500-22	BS-500-22		
24 Ga.	BG-500-24	BS-500-24		



ALL DIMENSION ARE NOMINAL SIZES

1" SNAPLOCK

SNAPLOCK			800 per box 26,400 per skid	
	GALVANIZED	STAINLESS STEEL		
24 Ga.	SG-114-24 embossed	SS-114-24 embossed		<p>PART SHOWN WITH EMBOSS</p>
	SG-114-24-NR w/o emboss	SS-114-24-NR w/o emboss		

1-1/2" SNAPLOCK

SNAPLOCK CLIP			500 per box 16,500 per skid	
	GALVANIZED	STAINLESS STEEL		
18 Ga.	SG-158-18	SS-158-18		

1-3/4" SNAPLOCK

PART #	QTY:		
SGUL-178-18 (Galvanized)	250 per box 8250 per skid		
SSUL-178-18 (Stainless Steel)			

SNAPLOCK CLIP			500 per box 16,500 per skid	
	GALVANIZED	STAINLESS STEEL		
18 Ga.	SG-178-18	SS-178-18		



ALL DIMENSION ARE NOMINAL SIZES

### ULTRALOK 2.0: 2" MECHANICAL LOCK

UL - FLOATING ARCHITECTURAL CLIPS			
PART #	"A" DIM.		
* NC-33001-3 (-S)	1/2"		NC-XXXXX-3   <b>STANDARD IN-STOCK BASE</b>
NC-33002-3 (-S)	1"		<p><b>TAB:</b> galvanized 22ga. <b>BASE:</b> galvanized 16ga. <b>PART WIDTH:</b> 4-1/4"</p>
NC-33001-6 (-S)	1/2"		NC-XXXXX-6   <b>OPTIONAL PURLIN STABILIZER</b>
NC-33002-6 (-S)	1"		<p><b>TAB:</b> galvanized 22ga. <b>BASE:</b> galvanized 16ga. <b>PART WIDTH:</b> 4-1/4"</p>
<b>QTY:</b>			
*(NC-33001-3) 120 per box 3960 per skid			
110 per box 3630 per skid			

UL - FLOATING ARCHITECTURAL CLIPS			
PART #	"A" DIM.		
NC-33003-3 (-S)	1/2"		NC-XXXXX-3   <b>STANDARD IN-STOCK BASE</b>
NC-33004-3 (-S)	1"		<p><b>TAB:</b> galvanized 22ga. <b>BASE:</b> galvanized 16ga. <b>PART WIDTH:</b> 4-1/4"</p>
NC-33003-6 (-S)	1/2"		NC-XXXXX-6   <b>OPTIONAL PURLIN STABILIZER</b>
* NC-33004-6 (-S)	1"		<p><b>TAB:</b> galvanized 22ga. <b>BASE:</b> galvanized 16ga. <b>PART WIDTH:</b> 4-1/4"</p>
<b>QTY:</b>			
110 per box 3630 per skid			
*(NC-33004-6) 100 per box 3300 per skid			

UL - FLOATING ARCHITECTURAL CLIPS			
PART #	"A" DIM.		
NC-33009-3 (-S)	1/2"		NC-XXXXX-3   <b>STANDARD IN-STOCK BASE</b>
NC-33010-3 (-S)	1"		<p><b>TAB:</b> galvanized 22ga. <b>BASE:</b> galvanized 16ga. <b>PART WIDTH:</b> 4-1/4"</p>
NC-33009-6 (-S)	1/2"		NC-XXXXX-6   <b>OPTIONAL PURLIN STABILIZER</b>
NC-33010-6 (-S)	1"		<p><b>TAB:</b> galvanized 22ga. <b>BASE:</b> galvanized 16ga. <b>PART WIDTH:</b> 4-1/4"</p>
<b>QTY:</b>			
110 per box 3630 per skid			



ALL DIMENSION ARE NOMINAL SIZES

ULTRALOK 2.0: 2" MECHANICAL LOCK

UL - FIXED CLIPS			
PART #	"A" DIM.		
NCF-33000 (-S)	0" CLEARANCE		<p>shown without clearance</p>
NCF-33001 (-S)	3/8" STANDOFF		
NCF-33002 (-S)	1-3/8" STANDOFF		
<b>QTY:</b>			<p>shown with clearance</p>
225 per box 7425 per skid			
22ga. galvanized			

FIXED			
	GALVANIZED	STAINLESS STEEL	
22 Ga.	FG-218-22	FS-218-22	
24 Ga.	FG-218-24	FS-218-24	
<b>300 per box 9,900 per skid</b>			

FLOATING INTERLOCKING BASE			
	GALVANIZED	STAINLESS STEEL	
22 Ga.	BG-300-22 w/o emboss	BS-300-22 w/o emboss	
	BGE-300-22 embossed	BSE-300-22 embossed	
<b>500 per box 33,000 per skid</b>			

FLOATING INTERLOCKING TAB			
	GALVANIZED	STAINLESS STEEL	
24 Ga.	TG3-200-24	TS3-200-24	
26 Ga.	TG3-200-26	TS3-200-26 NON-STOCK ITEM	
<b>400 per box 13,200 per skid</b>			

KNUDSON

KNUDSON





**ULTRALOK 2.0: 2" MECHANICAL LOCK**

ALL DIMENSION ARE NOMINAL SIZES

FLOATING SLOTTED TAB			500 per box 16,500 per skid	
	GALVANIZED	STAINLESS STEEL		
22 Ga.	TG-200-22	TS-200-22		SLOTTED BASE REQUIRED
24 Ga.	TG-200-24	TS-200-24		

FLOATING SLOTTED BASE			250 per box 16,500 per skid	
	GALVANIZED	STAINLESS STEEL		
16 Ga.	BG-500-16	BS-500-16		SLOTTED TAB REQUIRED
18 Ga.	BG-500-18	BS-500-18		
20 Ga.	BG-500-20	BS-500-20		
22 Ga.	BG-500-22	BS-500-22		
24 Ga.	BG-500-24	BS-500-24		

**KR-24: 2" MECHANICAL LOCK**

UL - FLOATING ARCHITECTURAL CLIPS				
PART #	"A" DIM.		NC-XXXXX-3   STANDARD IN-STOCK BASE	
* NC-33001-3 (-S)	1/2"			TAB: galvanized 22ga. BASE: galvanized 16ga. PART WIDTH: 4-1/4"
NC-33002-3 (-S)	1"			
NC-33001-6 (-S)	1/2"			
NC-33002-6 (-S)	1"			
QTY:		CLASSIFIED 	NC-XXXXX-6   OPTIONAL PURLIN STABILIZER	
* (NC-33001-3) 120 per box 3960 per skid				TAB: galvanized 22ga. BASE: galvanized 16ga. PART WIDTH: 4-1/4"
110 per box 3630 per skid				



ALL DIMENSION ARE NOMINAL SIZES

**KR-24: 2" MECHANICAL LOCK**

UL - FLOATING ARCHITECTURAL CLIPS				
PART #	"A" DIM.		NC-XXXXX-3   STANDARD IN-STOCK BASE	
NC-33009-3 (-S)	1/2"			TAB: galvanized 22ga. BASE: galvanized 16ga. PART WIDTH: 4-1/4"
NC-33010-3 (-S)	1"			
NC-33009-6 (-S)	1/2"			
NC-33010-6 (-S)	1"			
QTY:		CLASSIFIED 	NC-XXXXX-6   OPTIONAL PURLIN STABILIZER	
110 per box 3630 per skid				TAB: galvanized 22ga. BASE: galvanized 16ga. PART WIDTH: 4-1/4"

UL - FIXED CLIPS				
PART #	"A" DIM.		NC-XXXXX-3   STANDARD IN-STOCK BASE	
NCF-33005 (-S)	0" CLEARANCE			shown without clearance
NCF-33006 (-S)	1/2" STANDOFF			
NCF-33007 (-S)	1" STANDOFF			
QTY:		CLASSIFIED 	NC-XXXXX-6   OPTIONAL PURLIN STABILIZER	
225 per box 7425 per skid				shown with clearance
22ga. galvanized				

FIXED				
	GALVANIZED	STAINLESS STEEL		300 per box 9,900 per skid
22 Ga.	FG-218-22	FS-218-22		
24 Ga.	FG-218-24	FS-218-24		

KNUDSON

KNUDSON



ALL DIMENSION ARE NOMINAL SIZES

**KR-24: 2" MECHANICAL LOCK**

FLOATING INTERLOCKING BASE			500 per box 33,000 per skid	
	GALVANIZED	STAINLESS STEEL		 INTERLOCKING TAB REQUIRED
22 Ga.	BG-300-22 w/o emboss	BS-300-22 w/o emboss		
	BGE-300-22 embossed	BSE-300-22 embossed		

FLOATING INTERLOCKING TAB			400 per box 13,200 per skid	
	GALVANIZED	STAINLESS STEEL		 INTERLOCKING BASE REQUIRED
24 Ga.	TG3-200-24	TS3-200-24		
26 Ga.	TG3-200-26	TS3-200-26 NON-STOCK ITEM		

FLOATING SLOTTED BASE			250 per box 16,500 per skid	
	GALVANIZED	STAINLESS STEEL		 SLOTTED TAB REQUIRED
16 Ga.	BG-500-16	BS-500-16		
18 Ga.	BG-500-18	BS-500-18		
20 Ga.	BG-500-20	BS-500-20		
22 Ga.	BG-500-22	BS-500-22		
24 Ga.	BG-500-24	BS-500-24		

FLOATING SLOTTED TAB			500 per box 16,500 per skid	
	GALVANIZED	STAINLESS STEEL		 SLOTTED BASE REQUIRED
22 Ga.	TG-200-22	TS-200-22		
24 Ga.	TG-200-24	TS-200-24		



ALL DIMENSION ARE NOMINAL SIZES

**KR-18: 2-1/2" MECHANICAL LOCK**

FIXED CLIPS			300 per box 9900 per skid	
	GALVANIZED	STAINLESS STEEL		
22 Ga.	FG-258-22	FS-258-22		
24 Ga.	FG-258-24	FS-258-24		

FLOATING INTERLOCKING BASE			500 per box 33,000 per skid	
	GALVANIZED	STAINLESS STEEL		 INTERLOCKING TAB REQUIRED
22 Ga.	BG-300-22 w/o emboss	BS-300-22 w/o emboss		
	BGE-300-22 embossed	BSE-300-22 embossed		

FLOATING INTERLOCKING TAB			400 per box 33,000 per skid	
	GALVANIZED	STAINLESS STEEL		 INTERLOCKING BASE REQUIRED
24 Ga.	TG3-250-24	TS3-250-24		
26 Ga.	TG3-250-26	TS3-250-26 NON-STOCK ITEM		

FLOATING SLOTTED TAB			500 per box 16,500 per skid	
	GALVANIZED	STAINLESS STEEL		 SLOTTED BASE REQUIRED
22 Ga.	TG-250-22	TS-250-22		
24 Ga.	TG-250-24	TS-250-24		

KNUDSON

KNUDSON



ALL DIMENSION ARE NOMINAL SIZES

**KR-18: 2-1/2" MECHANICAL LOCK**

FLOATING SLOTTED BASE			250 per box 16,500 per skid	
	GALVANIZED	STAINLESS STEEL		
16 Ga.	<b>BG-500-16</b>	<b>BS-500-16</b>		<p><b>SLOTTED TAB REQUIRED</b></p>
18 Ga.	<b>BG-500-18</b>	<b>BS-500-18</b>		
20 Ga.	<b>BG-500-20</b>	<b>BS-500-20</b>		
22 Ga.	<b>BG-500-22</b>	<b>BS-500-22</b>		
24 Ga.	<b>BG-500-24</b>	<b>BS-500-24</b>		

**KR-16: 3" MECHANICAL LOCK**

FIXED CLIPS			200 per box 6,600 per skid	
	GALVANIZED			
22 Ga.	<b>FG-300-0.75-22</b>			
24 Ga.	<b>FG-300-0.75-24</b>			

FIXED CLIPS			200 per box 6,600 per skid		
	GALVANIZED	STAINLESS STEEL			
22 Ga.	<b>FG-300-22</b>	<b>FS-300-22</b>			
24 ga.	<b>FG-300-24</b>	<b>FS-300-24</b>			



ALL DIMENSION ARE NOMINAL SIZES

**KR-16: 3" MECHANICAL LOCK**

FLOATING INTERLOCKING BASE			500 per box 33,000 per skid	
	GALVANIZED	STAINLESS STEEL		
22 Ga.	<b>BG-300-22</b> w/o emboss	<b>BS-300-22</b> w/o emboss		<p><b>INTERLOCKING TAB REQUIRED</b></p>
	<b>BGE-300-22</b> embossed	<b>BSE-300-22</b> embossed		

FLOATING INTERLOCKING TAB			500 per box 3,300 per skid	
	GALVANIZED	STAINLESS STEEL		
24 Ga.	<b>TG3-300-24</b>	<b>TS3-300-24</b>		<p><b>INTERLOCKING BASE REQUIRED</b></p>

FLOATING SLOTTED BASE			250 per box 16,500 per skid	
	GALVANIZED	STAINLESS STEEL		
16 Ga.	<b>BG-500-16</b>	<b>BS-500-16</b>		<p><b>SLOTTED TAB REQUIRED</b></p>
18 Ga.	<b>BG-500-18</b>	<b>BS-500-18</b>		
20 Ga.	<b>BG-500-20</b>	<b>BS-500-20</b>		
22 Ga.	<b>BG-500-22</b>	<b>BS-500-22</b>		
24 Ga.	<b>BG-500-24</b>	<b>BS-500-24</b>		

FLOATING SLOTTED TAB			500 per box 16,500 per skid	
	GALVANIZED	STAINLESS STEEL		
22 Ga.	<b>TG-300-22</b>	<b>TS-300-22</b>		<p><b>SLOTTED BASE REQUIRED</b></p>
24 Ga.	<b>TG-300-24</b>	<b>TS-300-24</b>		

KNUDSON

KNUDSON



## QUADRO PRO

### 1" MECHANICAL LOCK:

FIXED			500 per box 3,300 per skid	
	GALVANIZED	STAINLESS STEEL		
22 Ga.	QP-SG2-094-22	QP-SS2-094-22		
24 Ga.	QP-SG2-094-24	QP-SS2-094-24		

### 1.5" MECHANICAL LOCK

FIXED			500 per box 16,500 per skid	
24 Ga.	QP-FG3-150-24	QP-FS3-150-24		
26 Ga.	QP-FG3-150-26	QP-FS3-150-26		
24 Ga.	QP-FG6-150-24	QP-FS6-150-24		
26 Ga.	QP-FG6-150-26	QP-FS6-150-26		

### 1.5" SNAPLOCK

SNAPLOCK			500 per box 16,500 per skid	
18 Ga.	QP-SG-150-18	QP-SS-150-18		



ALL DIMENSION ARE NOMINAL SIZES

### 2" MECHANICAL LOCK

UL - FLOATING ARCHITECTURAL CLIPS				
<b>PART #</b>	<b>"A" DIM.</b>		NC-XXXX-3   <b>STANDARD IN-STOCK BASE</b>	
NC-33013-3 (-S)	1/2"			<b>TAB:</b> galvanized 22ga. <b>BASE:</b> galvanized 16ga. <b>PART WIDTH:</b> 4-1/4"
NC-33014-3(-S)	1"			
NC-33013-6 (-S)	1/2"			NC-XXXX-6   <b>OPTIONAL PURLIN STABILIZER</b>
NC-33014-6 (-S)	1"			<b>TAB:</b> galvanized 22ga. <b>BASE:</b> galvanized 16ga. <b>PART WIDTH:</b> 4-1/4"
<b>QTY:</b>		110 per box 3630 per skid		

FIXED			300 per box 9,900 per skid	
	GALVANIZED	STAINLESS STEEL		
22 Ga.	QP-FG-200-22	QP-FS-200-22		
24 Ga.	QP-FG-200-24	QP-FS-200-24		
22 Ga.	QP-FG-218-22	QP-FS-218-22		
24 Ga.	QP-FG-218-24	QP-FS-218-24		

QUADRO PRO

QUADRO PRO

2" MECHANICAL LOCK

ALL DIMENSION ARE NOMINAL SIZES

FLOATING SLOTTED BASE			250 per box 16,500 per skid	
	GALVANIZED	STAINLESS STEEL		
16 Ga.	<b>BG-500-16</b>	<b>BS-500-16</b>	<p><b>SLOTTED TAB REQUIRED</b></p>	
18 Ga.	<b>BG-500-18</b>	<b>BS-500-18</b>		
20 Ga.	<b>BG-500-20</b>	<b>BS-500-20</b>		
22 Ga.	<b>BG-500-22</b>	<b>BS-500-22</b>		
24 Ga.	<b>BG-500-24</b>	<b>BS-500-24</b>		

FLOATING SLOTTED TAB			500 per box 3,300 per skid	
	GALVANIZED	STAINLESS STEEL		
22 Ga.	<b>QP-TG-200-22</b>	<b>QP-SS-200-22</b>	<p><b>SLOTTED BASE REQUIRED</b></p>	
24 Ga.	<b>QP-TG-200-24</b>	<b>QP-SS-150-24</b>		

ULTRA SEAM

**US-150 & US-150C:**  
1 1/2" MECHANICAL LOCK & 1-1/2" MECHANICAL LOCK CURVED

FIXED			500 per box 16,500 per skid	
	GALVANIZED	STAINLESS STEEL		
24 Ga.	<b>FG--158-24</b>	<b>FS-158-24</b>		
26 Ga.	<b>FG-158-26</b>	<b>FS-158-26</b>		

FIXED			200 per box 6,600 per skid	
	GALVANIZED	STAINLESS STEEL		
24 Ga.	<b>FG6-158-24</b>	<b>FS6-158-24</b>		
26 Ga.	<b>FG6-158-26</b>	<b>FS6-158-26</b>		

FLOATING INTERLOCKING BASE			500 per box 33,000 per skid	
	GALVANIZED	STAINLESS STEEL		
22 Ga.	<b>BG-300-22</b> w/o emboss	<b>BS-300-22</b> w/o emboss	<p><b>INTERLOCKING TAB REQUIRED</b></p>	
	<b>BGE-300-22</b> embossed	<b>BSE-300-22</b> embossed		

FLOATING INTERLOCKING TAB			500 per box 33,000 per skid	
	GALVANIZED	STAINLESS STEEL		
24 Ga.	<b>TG3-150-24</b>	<b>TS3-150-24</b>	<p><b>INTERLOCKING BASE REQUIRED</b></p>	

ALL DIMENSION ARE NOMINAL SIZES

QUADRO PRO

ULTRA SEAM



ALL DIMENSION ARE NOMINAL SIZES

**US-150 & US-150C: 1-1/2" MECHANICAL LOCK**

FLOATING SLOTTED TAB			500 per box 16,500 per skid	
	GALVANIZED	STAINLESS STEEL		
24 Ga.	TG-150-24	TS-150-24		
26 Ga.	TG-150-26	TS-150-26		

FLOATING SLOTTED BASE			250 per box 16,500 per skid	
	GALVANIZED	STAINLESS STEEL		
16 Ga.	BG-500-16	BS-500-16		
18 Ga.	BG-500-18	BS-500-18		
20 Ga.	BG-500-20	BS-500-20		
22 Ga.	BG-500-22	BS-500-22		
24 Ga.	BG-500-24	BS-500-24		

**US-150LS: 1-1/2" SNAPLOCK**

UL - SNAPLOCK		300 per box 9,900 per skid	
<b>PART #</b>	<b>QTY:</b>		
SSUL - 196 - 20 Stainless Steel	300 per box 9,900 per skid		

**US-150LS: 1-1/2" SNAPLOCK**

ALL DIMENSION ARE NOMINAL SIZES

SNAPLOCK			300 per box 9,900 per skid	
	GALVANIZED	STAINLESS STEEL		
20 Ga.	SG-196-20			
22 Ga.	SG-196-22			

SNAPLOCK			500 per box 16,500 per skid	
	GALVANIZED	STAINLESS STEEL		
24 Ga.	SG2-196-24	SS2-196-24		

**US-175LS: 1-3/4" SNAPLOCK**

UL - SNAPLOCK		250 per box 8250 per skid	
<b>PART #</b>	<b>QTY:</b>		
SGUL-178-18 (Galvanized)	250 per box 8250 per skid		
SSUL-178-18 (Stainless Steel)			

SNAPLOCK			500 per box 16,500 per skid	
	GALVANIZED	STAINLESS STEEL		
18 Ga.	SG-178-18	SS-178-18		

ULTRA SEAM

ULTRA SEAM



ALL DIMENSION ARE NOMINAL SIZES

**US-200 & US-200C:**  
2" MECHANICAL LOCK / 2" MECHANICAL LOCK CURVED

UL - FLOATING ARCHITECTURAL CLIPS				
PART #	"A" DIM.		NC-XXXXX-3   STANDARD IN-STOCK BASE	
NC-33001-3 (-S)	1/2"			<b>TAB:</b> galvanized 22ga. <b>BASE:</b> galvanized 16ga. <b>PART WIDTH:</b> 4-1/4"
NC-33002-3 (-S)	1"			<b>TAB:</b> galvanized 22ga. <b>BASE:</b> galvanized 16ga. <b>PART WIDTH:</b> 4-1/4"
NC-33001-6 (-S)	1/2"			
NC-33002-6 (-S)	1"			
<b>QTY:</b>				
*(NC-33001-3) 120 per box 3960 per skid				
110 per box 3630 per skid				

UL - FLOATING ARCHITECTURAL CLIPS				
PART #	"A" DIM.		NC-XXXXX-3   STANDARD IN-STOCK BASE	
NC-33003-3 (-S)	1/2"			<b>TAB:</b> galvanized 22ga. <b>BASE:</b> galvanized 16ga. <b>PART WIDTH:</b> 4-1/4"
NC-33004-3 (-S)	1"			<b>TAB:</b> galvanized 22ga. <b>BASE:</b> galvanized 16ga. <b>PART WIDTH:</b> 4-1/4"
NC-33003-6 (-S)	1/2"			
* NC-33004-6 (-S)	1"			
<b>QTY:</b>				
110 per box 3630 per skid				
*(NC-33004-6) 100 per box 3300 per skid				

UL - FLOATING ARCHITECTURAL CLIPS				
PART #	"A" DIM.		NC-XXXXX-3   STANDARD IN-STOCK BASE	
NC-33009-3 (-S)	1/2"			<b>TAB:</b> galvanized 22ga. <b>BASE:</b> galvanized 16ga. <b>PART WIDTH:</b> 4-1/4"
NC-33010-3 (-S)	1"			<b>TAB:</b> galvanized 22ga. <b>BASE:</b> galvanized 16ga. <b>PART WIDTH:</b> 4-1/4"
NC-33009-6 (-S)	1/2"			
NC-33010-6 (-S)	1"			
<b>Qty:</b>				
110 per box 3630 per skid				



US-200 & US-200C: 2" MECHANICAL LOCK

ALL DIMENSION ARE NOMINAL SIZES

UL - FIXED CLIPS			
PART #	"A" DIM.		
NCF-33005 (-S)	0" CLEARANCE		
NCF-33006 (-S)	1/2" STANDOFF		
NCF-33007 (-S)	1" STANDOFF		
<b>QTY:</b>			
225 per box 7425 per skid			
22ga. galvanized			

FIXED				300 per box 9,900 per skid
	GALVANIZED	STAINLESS STEEL		
22 Ga.	FG-218-22	FS-218-22		
24 Ga.	FG-218-24	FS-218-24		

FLOATING INTERLOCKING BASE				500 per box 33,000 per skid
	GALVANIZED	STAINLESS STEEL		
22 Ga.	BG-300-22 w/o emboss	BS-300-22 w/o emboss		
	BGE-300-22 embossed	BSE-300-22 embossed		

FLOATING INTERLOCKING TAB				400 per box 13,200 per skid
	GALVANIZED	STAINLESS STEEL		
24 Ga.	TG3-200-24	TS3-200-24		
26 Ga.	TG3-200-26	TS3-200-26 NON-STOCK ITEM		

ULTRA SEAM

ULTRA SEAM

ALL DIMENSION ARE NOMINAL SIZES

US-200 & US-200C: 2" MECHANICAL LOCK

FLOATING SLOTTED BASE			250 per box 16,500 per skid
	GALVANIZED	STAINLESS STEEL	
16 Ga.	BG-500-16	BS-500-16	
18 Ga.	BG-500-18	BS-500-18	
20 Ga.	BG-500-20	BS-500-20	
22 Ga.	BG-500-22	BS-500-22	
24 Ga.	BG-500-24	BS-500-24	

FLOATING SLOTTED TAB			500 per box 16,500 per skid
	GALVANIZED	STAINLESS STEEL	
22 Ga.	TG-200-22	TS-200-22	
24 Ga.	TG-200-24	TS-200-24	

# H/C Rake & Eave Plates

## HIGH CAPACITY RAKE & EAVE PLATES

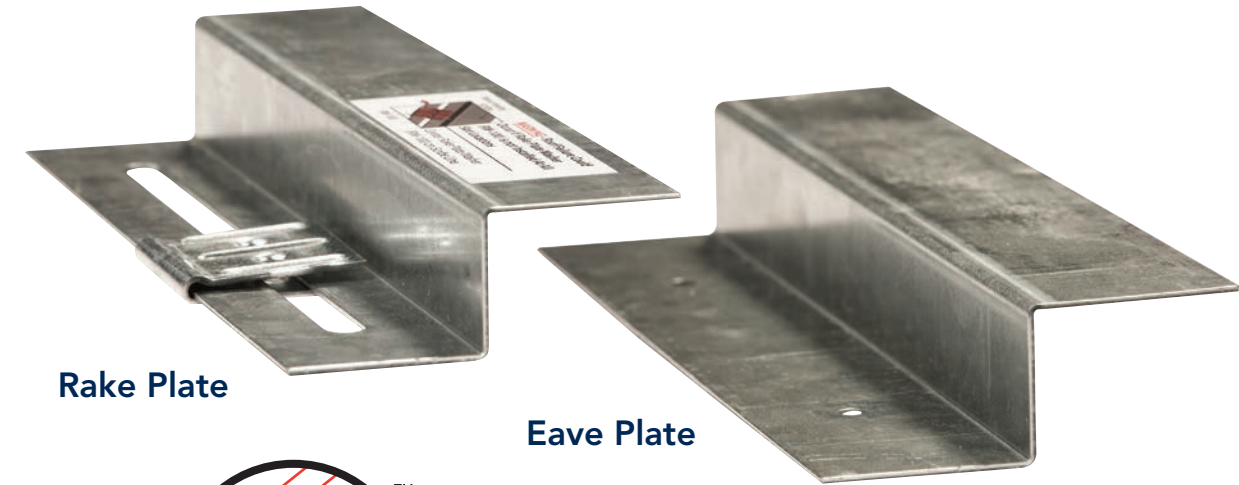

Rake Plate

Eave Plate



DESIGNING FOR TOMORROW'S CODES - TODAY

The Design and Engineering group at Building Research Systems, Inc. has come to represent forward thinking through continuing improvements and innovations of premier metal standing seam roofing systems and accessories. Their incessant desire to improve the industry's standing seam roof systems has led to yet another benchmark performance enhancement with the innovation of the patented High Capacity Rake and Eave plates. These patented designed components were engineered in part due to the upcoming more stringent ASCE 7 edge /corner zone uplift requirements for all metal standing seam roof systems. These high performance parts were also developed with the new MBC/MBMA inspired edge metal testing protocol in mind coupled with the need for a longer travel slide to match the roof clips capabilities for thermal expansion and contraction. These patented revolutionary parts provide a standing seam roofing system critical edge/corner zone uplift capabilities that out performs all other systems currently on the market today.

### Benefits at a Glance

1. High Capacity Rake and Eave Plate designs for the critical edge/corner zones tested to be significantly stronger than the current designs in service. However, the new patented parts only lose serviceability performance (movement for thermal expansion) due to the unique design of the retainer parts clamping design which allows the roof to remain intact preventing possible catastrophic roof loss.
2. The variety of vertical web depth availability of the new parts work with the standing seam industry standard clip heights of 1/2", 1", 1-1/2" and 2" as well as the taller standoff clip heights of 2-1/2" and 3". Custom heights are available. The parts designs work with new or retrofit roof applications that utilize the taller standoff clips in their construction design.
3. High Capacity Rake/Eave plate parts are formed using 16 -gauge G-90 galvanized steel construction for durability and maximum performance for panel and/or trim attachments.
4. Extended horizontal 2" top/bottom leg flanges on both the rake and eave plate parts provide an ample stable attachment contact surface for the installer assuring a weather-tight seal along with superior uplift performance when installed correctly with the proper sealants and fasteners. This allows individual panel manufacturers freedom for their specific or unique trim design.

ULTRA SEAM





# HIGH CAPACITY RAKE & EAVE PLATES



## Benefits at a Glance continued

5. Pre-punched High Capacity Rake plates have 3/8" X 8-1/4" slots on 18" centers down the 10'-0" length of the part. These slots allow quick attachment using seven (7) factory installed rake plate retainer parts using two 1/4-14 fasteners per retainer to the sub-structure. The RP retainer parts are field aligned during installation with the scribed vertical leg guide lines which indicates the center point of each slot for proper attachment.
6. An instructional decal is permanently adhered to one end of the rake part for field installation directions, assuring the installer proper procedures for correct RP retainer part location/attachment.
7. The unique slot/retainer part design of the High Capacity Rake plate allows for maximum thermal expansion contraction for up to 7" overall slide travel.
8. All High Capacity Eave plates are pre-punched with 1/4" round fastener attachment holes at 6" on center down the full length of the part. The pre-punched round holes aid in the installation of the 16-gauge galvanized part for simplification of install and proper fastener location. These pre-punched holes assure all parties maximum uplift performance when the correct fasteners are properly installed during erection.
9. All parts are supplied in convenient ten foot (10'-0) lengths for ease of jobsite handling and quicker field installations.
10. The part designs are independent laboratory third party tested for performance with assigned design values. The forward thinking design will meet or exceed the more stringent anticipated ASCE 7 corner/edge zone uplift loads for all metal standing seam roof systems that will shortly be imposed. The part testing also assures that it will not be the weak link in the upcoming MCA/MBMA inspired edge metal test protocol.
11. Supports architects, specification writers, and owners' requirements for thicker fiberglass blanket insulation systems for ever increasing green design higher "R" and lower "U" values mandated code needs.
12. The need for dual attachment fastener type inventory will be eliminated since the high capacity rake/eave plate design uses the same 1/4-14 screws (no shoulder fasteners required) for connecting to the structural support system. The elimination of shoulder fasteners removes the possibility of an improper install in the wrong location.
13. The eave plate pre-punched holes, as well as the factory pre-assembled rake, with the retainer parts placed into the slots make for a quicker installation and an erector friendly experience for proper fastener placement.
14. The unique patented design provides more stiffness for the standing seam roof diaphragm during testing.

The design and engineering of these parts meet the need for tomorrow's more stringent corner/edge zones uplift codes, TODAY. Contact BPD today for the highest performing patented High Capacity Rake/Eave plate technology available within the industry.

ALL DIMENSION ARE NOMINAL SIZES

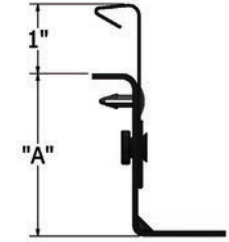
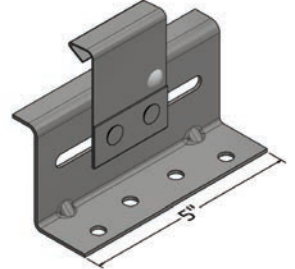
## BPD, Inc. MISCELLANEOUS

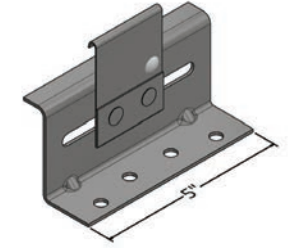
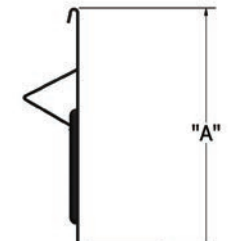
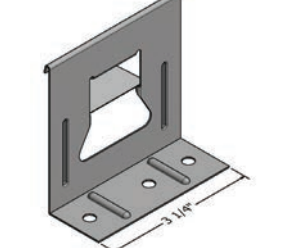
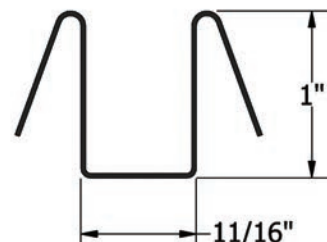
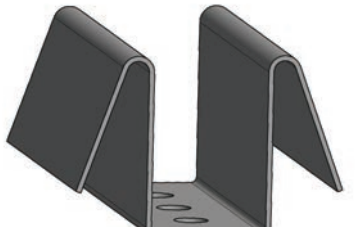
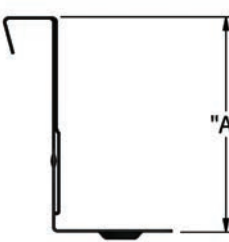
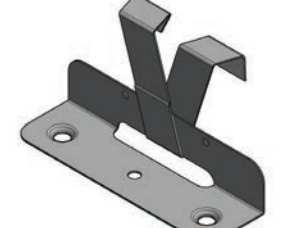
<b>PART NUMBER</b>	<b>A DIM.</b>		
<b>BW-2122</b>	2-1/2"		
<b>BW-2124</b>	3-1/2"		
<b>PART NUMBER</b>	<b>A DIM.</b>		
<b>BW-2102</b>	2-1/2"		
<b>BW-2104</b>	3-1/2"		
<b>PART NUMBER</b>	<b>A DIM.</b>		
<b>BW-200</b>	3"		
<b>BW-204</b>	3.25"		
<b>BW-208</b>	4.25"		
<b>ED-0062</b>			
24 ga. G-90 Galvanized Steel			
<b>BUTTERFLY</b>	<b>A DIM.</b>		
<b>NB-150</b>	1-1/2"		
<b>NB-100</b>	1"		

ALL DIMENSION ARE NOMINAL SIZES

<b>NC-33015-3(-S)</b> <b>&amp; NC-33015-6(-S)</b>					
<b>Tab:</b> 22ga. G90 Galvanized <b>Base:</b> 16ga. Galvanized Factory Applied Sealant Optional					

<b>NC-33017-6</b> <b>&amp; NC-33017-6-SS</b>			
<b>Tab:</b> 22ga. G90 Galvanized & 22ga Stainless Steel <b>Base:</b> 16 ga. Galvanized			

<b>NC-33018-TTS</b>			
<b>Tab:</b> 22ga. Stainless Steel <b>Base:</b> 16ga. Galvanized Factory Applied Sealant Optional			

<b>NC-33025-3 &amp;</b> <b>NC-33025-3-SS</b>			
<b>Tab:</b> 22ga. G90 Galvanized & 22ga. Stainless Steel <b>Base:</b> 16 ga. Galvanized Factory Applied Sealant Optional			

PART NUMBER	"A"			
<b>NC-34500-3 (-S)</b>	<b>2"</b>			
<b>NC-34500-6 (-S)</b>	<b>2"</b>			
<b>NC-34501-3 (-S)</b>	<b>2-1/4"</b>			
<b>NC-34501-6 (-S)</b>	<b>2-1/4"</b>			
<b>NC-34502-3 (-S)</b>	<b>3-1/4"</b>			
<b>NC-34502-6 (-S)</b>	<b>3-1/4"</b>	<b>Tab:</b> 22ga. G90 Galvanized <b>Base:</b> 16 ga. Galvanized Factory Applied Sealant Optional		

ALL DIMENSION ARE NOMINAL SIZES

PART NUMBER	"A"		
<b>NC-34508-3 (-S)</b>	<b>1-3/4"</b>		
<b>NC-34509-3 (-S)</b>	<b>2-1/8"</b>		
<b>NC-34510-3 (-S)</b>	<b>2-3/4"</b>		
<b>NC-34511-3 (-S)</b>	<b>3-1/8"</b>		
<b>Tab:</b> 22ga. G90 Galvanized <b>Base:</b> 16 ga. Galvanized Factory Applied Sealant Optional			

PART NUMBER	"A"		
<b>NC-34521-3 (-S)</b>	<b>1-7/8"</b>		
<b>NC-34522-3 (-S)</b>	<b>2-7/8"</b>		
<b>Tab:</b> 22ga. G90 Galvanized <b>Base:</b> 16ga. Galvanized Factory Applied Sealant Optional			

PART NUMBER	"A"		
<b>NC-34523-3 (-S)</b>	<b>1-5/8"</b>		
<b>NC-34524-3 (-S)</b>	<b>2-5/8"</b>		
<b>Tab:</b> 22ga. G90 Galvanized <b>Base:</b> 16ga. Galvanized Factory Applied Sealant Optional			

PART NUMBER		"A"		
<b>BCG-100-24</b>	<b>24 ga.</b>	<b>7/8"</b>		
<b>BCG-100-26</b>	<b>26 ga</b>	<b>7/8"</b>		
<b>BCG-075-24</b>	<b>24 ga</b>	<b>5/8"</b>		
<b>BCG-075-26</b>	<b>26 ga</b>	<b>5/8"</b>		
Available in galvanized and stainless steel. Call for pricing! (866) 766-3254				

ALL DIMENSION ARE NOMINAL SIZES

TILE CLIPS SS			
26 ga. Stainless Steel			

BERMUDA CLIPS			
FGB-187-24	24 ga.		
FSB-187-24	24 ga.		
FGB-187-26	26 ga		
FSB-187-26	26 ga.		

BERMUDA CLIPS			
FGB-200-24	24 ga.		
FSB-200-24	24 ga.		
FGB-200-26	26 ga		
FSB-200-26	26 ga.		

PART NUMBER	"A"	"B"
C401(S)	1"	1"
C402(S)	1"	2-1/4"
C403(S)	1"	3-1/4"
C451(S)	7/8"	1"
C452(S)	7/8"	2-1/4"
C453(S)	7/8"	3-1/4"

C401 & C402

C403

C451 & C452

C453

**TAB:** 20 ga. 50 ksi galvalume/galvanized  
**BASE:** 24 ga. g-90 galvalume/ galvalume  
 Factory Applied Sealant Optional

ALL DIMENSION ARE NOMINAL SIZES

# BPD, Inc. ACCESSORIES

GUTTER HANGER		
PART #	"A" DIM.	
GH-5	5"	
GH-6	6"	
GH-7	7"	
GH-8	8"	
16 ga. Galvanized Steel		

UNIVERSAL BEARING PLATE		
<b>BPG-4X5-16-1-2S</b>		
16 ga. Galvanized		
Visit <a href="http://wegotclips.com">wegotclips.com</a> for other available bearing plates		

GUTTER SUPPORT NORTHERN		
<b>CC 602</b>		
G-90 Galvanized 50ksi		

BACK-UP PLATE		
<b>BP 324</b>		
16 ga. Galvanized		

GUTTER SUPPORT SOUTHERN		
<b>CC 601</b>		
G-90 Galvanized 50ksi		

INSIDE CLOSURE		
<b>CC 324</b>		
24 ga. Galvanized		
<b>CC 324 - 18</b>		
18 ga. Galvalume		

48" ENDLAP BACK-UP CHANNEL		
<b>BP 148</b>		
16 ga. Galvanized Steel		

72" ENDLAP BACK-UP CHANNEL		
<b>BP 172</b>		
16 ga. Galvanized Steel		

ALL DIMENSION ARE NOMINAL SIZES

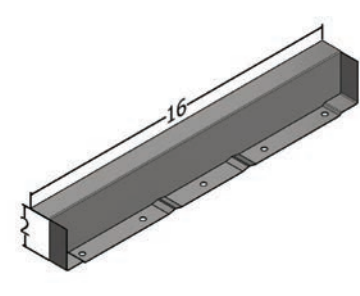
<b>OUTSIDE CLOSURE</b>	
<b>FED 216</b> 24 ga. Galvanized Steel	

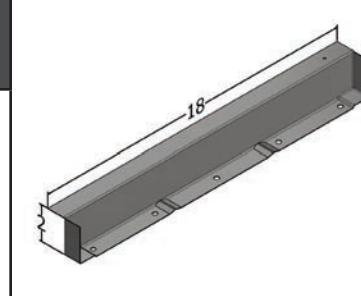
<b>OUTSIDE CLOSURE</b>	
<b>FED 218</b> 24 ga. Galvanized Steel	

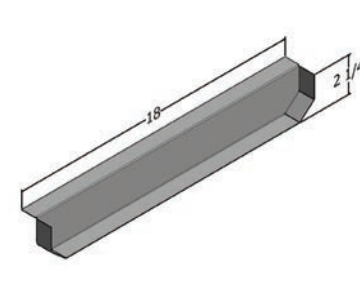
<b>END DAM</b>	
<b>ED-TRQ250</b> 24 ga. Galvalume	

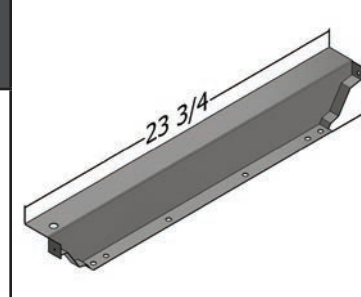
<b>END DAM</b>	
<b>ED 324</b> 24 ga., Zinalume, Galvanized (5oz coating)	

<b>16" ENDLAP CINCH PLATE</b>	
<b>CS 116</b> 20 ga. Stainless Steel	

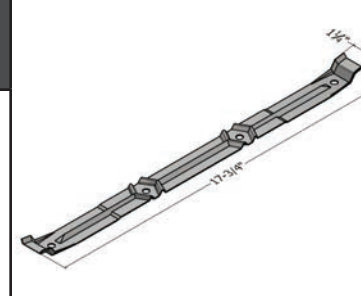
<b>18" ENDLAP CINCH PLATE</b>	
<b>CS 118</b> 20 ga. Stainless Steel	

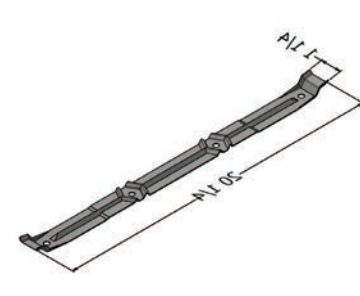
<b>CINCH STRAP</b>	
<b>CS 324</b> 20 ga. Stainless Steel	

ALL DIMENSION ARE NOMINAL SIZES

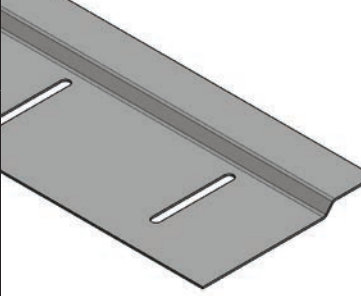
<b>PERIMETER PLATE LOW</b>	
<b>PP038</b> 16 ga. Galvanized Steel	

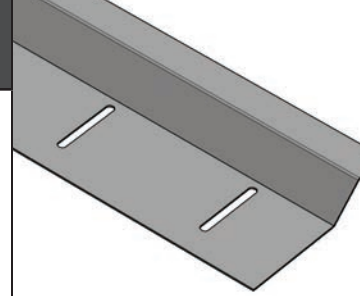
<b>PERIMETER PLATE HIGH</b>	
<b>PP138</b> 16 ga. Galvanized Steel	

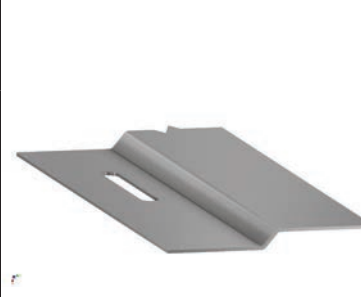
<b>PERIMETER PLATE-LOW</b>	
<b>RP 038</b> 16 ga. Galvanized Steel	

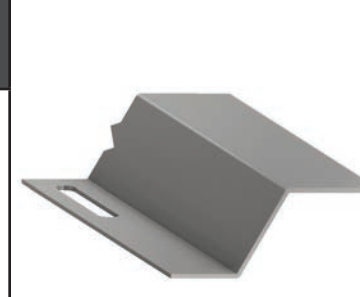
<b>PERIMETER PLATE-HIGH</b>	
<b>RP 138</b> 16 ga. Galvanized Steel	

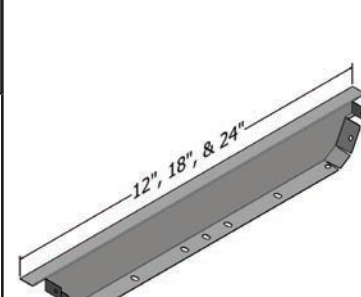
<b>OUTSIDE CLOSURE</b>	
<b>BW-430</b> 24 ga. Galvanized Steel	

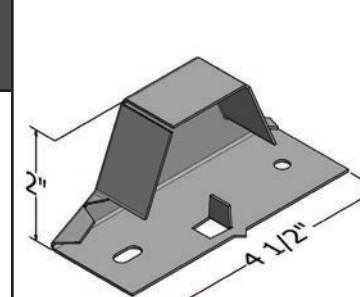
<b>INSIDE CLOSURE</b>	
<b>BW-426</b> 18 ga. Galvanized Steel	



A Member of **LSI GROUP**  
METAL BUILDING COMPONENTS

# RETROFIT PRODUCTS

(800) 771-1711  
sales@roofhugger.com  
www.roofhugger.com

### MODEL "C"

This part is 1.83" tall and designed to accommodate existing ribbed metal roofing panels with 1-1/2" or less major ribs spaced at 12" on center.

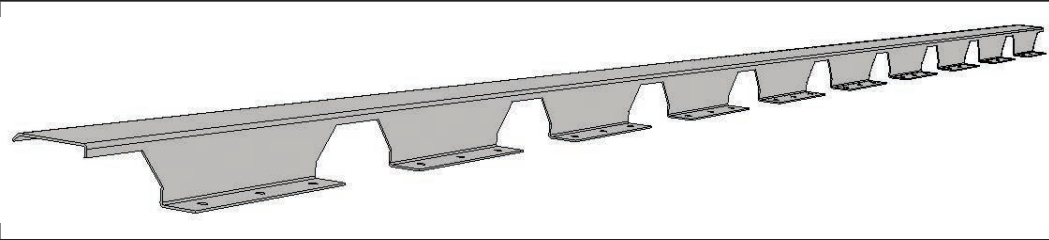

### MODEL "D"

This part is 4.5" tall and designed to accommodate existing 24" o.c. Trapezoidal SSR metal roof panels that do not have tall clips and thermal spacers.

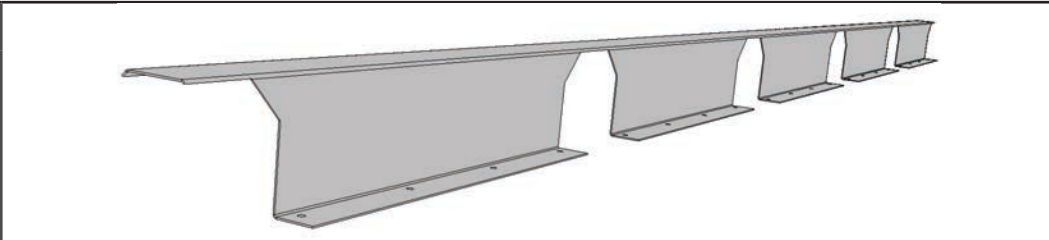

### MODEL "T"

This part is 4.5" tall and designed with a patented anti-rotational arm to accommodate existing 24" o.c. Trapezoidal SSR metal roof panels that are installed with tall clips and/or thermal spacers.

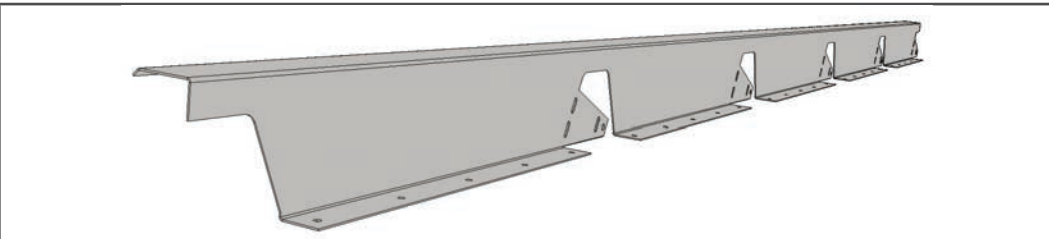

### CUSTOM HUGGERS

This term refers to ROOF HUGGER Sub-Purlins that are produced to a non-standard panel profile or height to accommodate the project needs.

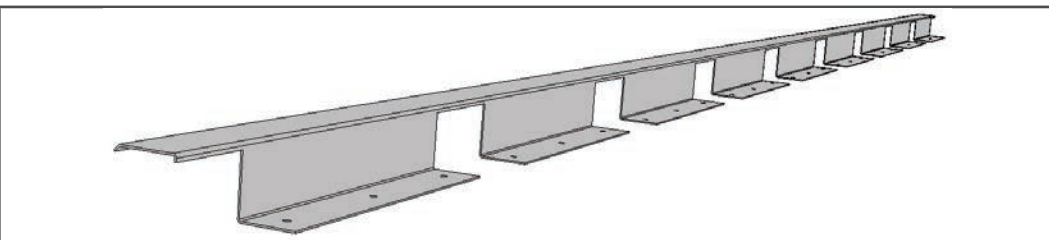

### CORRU-FIT<sup>®</sup> HUGGERS

This system is a 2.75" total height 2 piece assembly consisting of a 1.25" or 1.625" spacer mounted under a 1.625" or 1.125" respective Zee, with slots in the base flange specifically designed for corrugated roofs.



### Structural Hat Sections

- Five sizes to choose from
- Lengths available from 6ft. to 21 ft.
- All have 2" wide top flanges
- All hats are 16ga. 50 KSI A653 SS grade steel
- all are roll-formed from g90 pre-galvanized coil

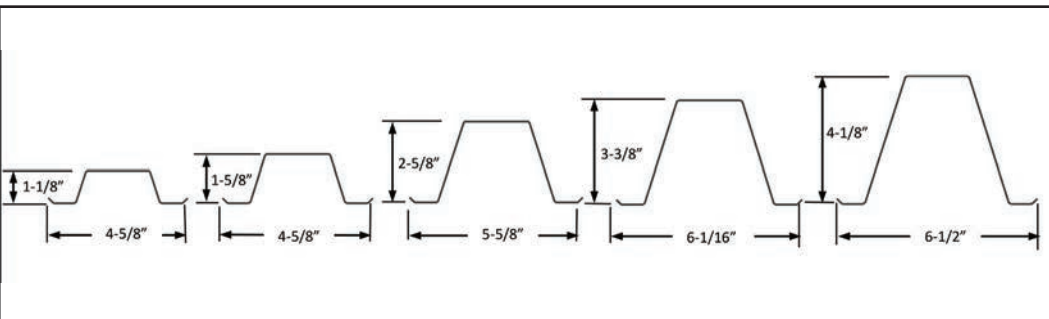

## Are you a **Contractor** looking for **Clips & Accessories**



(866) 766-3254  
wegotclips.com

BPD supplies contractors with clips and accessories for the following roof systems: New Tech, Englert, Ultra Seam, Zimmerman, Knudson, Rollformer, Schleich, Quadra-Pro™ & more!

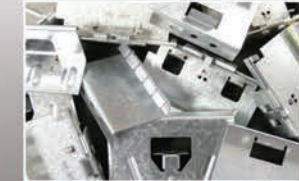

## Are you looking for **Retrofit Metal Roof Systems**



(800) 771-1711  
RoofHugger.com

Roof Hugger supplies any industry with factory-notched sub-purlin systems for all standing seam panel systems, thru-fastened roofs and corrugated. Don't replace your roof - retrofit it with Roof Hugger!



## Are you a **Manufacturer** looking for **Clips & Accessories**



(574) 722-3101  
LoganStampings.com

Logan Stampings supplies metal building and metal roof manufactures with clips and accessories!

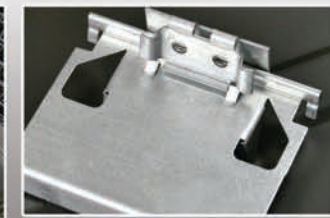
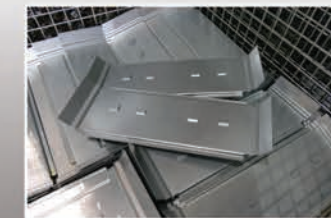

**All under one roof!**

Logan Stampings - BPD - Roof Hugger



**LOGAN**  
STAMPINGS



**LSI** METAL FABRICATION, INC.  
*Precision Metal Products & Services*



MEMBERS OF



WEGOTCLIPS.COM | (866) 766-3254